

Fisher™ C1

Pneumatic Controllers and Transmitters



Fisher C1 controllers and transmitters continue the tradition of durable and dependable Fisher pressure instrumentation while addressing air/gas consumption concerns. The C1 is used wherever durable and dependable pressure instrumentation is required. The use of this product in demanding applications, such as those found in chemical process, gas and oil production industries, demonstrates its versatility. The C1 can reduce steady-state air/gas consumption to as little as 1/10th that of previous products.

C1 controllers compare sensed process pressure (or differential pressure) with an operator-adjusted set point and send a pneumatic signal to an adjacent control element that maintains the process pressure at or near the set point value. C1 transmitters sense process variables and send out a pneumatic signal, usually to an indicating or recording device that directly indicates the process measurement.

Unless otherwise noted, all NACE references are to NACE MR0175 / ISO15156 and NACE MR0103.

Features

- **Wide Range of Sensing Elements** — A Bourdon tube is available for high pressures or bellows for vacuum and low pressures. Either kind of sensing element can be installed in the case with the controller or transmitter. Two interchangeable ranges of output bellows and gauges also are available.
- **Reduced Air/Gas Consumption** — The C1 pneumatic controller is an energy efficient choice, helping to improve profits and uptime. Steady-state consumption rate is less than the 6 scfh requirement set for the oil and gas industry by the US Environmental Protection Agency (New Source Performance Standards Subpart OOOO, EPA-HQ-QAR-2010-0505).
- **Sour Service Capability** — Materials are available for applications handling sour process fluids. These constructions comply with the metallurgical requirements of NACE MR0175 / ISO15156 and NACE MR0103. Environmental restrictions may apply.
- **Mounting Versatility** — Install the case on a panel, wall or pipestand, as well as directly on the control valve actuator.
- **Reduced Maintenance Costs** — A spring-out cleaning wire, shown in Figure 5, provides for in-service cleaning of the relay orifice.
- **Proportional-Only, Proportional-Plus-Reset and Differential Gap Configurable** — The C1 controller can be configured to provide various modes of control.
- **Field Reversible** — Switch action from direct to reverse or vice versa without additional parts. As illustrated in Figure 4, transfer the reversing block to the opposite side of the flapper, invert the proportional band assembly and change the feedback bellows tubing connections.
- **Easy, More Accurate Adjustments** — Make pressure set point, proportional band and reset changes with simple dial-knob controls that help to assure positive settings.
- **Sensitive Response** — Area ratio of large relay diaphragm to small relay diaphragm permits small nozzle pressure changes to induce much greater output pressure changes.

Figure 1. Fisher C1 Pneumatic Controller Yoke-Mounted on Control Valve Actuator



W9263-1

Table 1. Specifications

Available Configurations	Supply and Output Connections
See Table 2	1/4 NPT internal
Input Signal	Supply and Output Pressure Gauge Ranges
<p>Pressure</p> <p>Type: ■ Gauge pressure, ■ vacuum, ■ compound pressure or ■ differential pressure of a liquid or gas</p> <p>Limits: See Table 3 or 4</p>	See Table 6
Output Signal	Proportional Band Adjustment
<p>Proportional or Proportional-Plus-Reset Controllers and Transmitters: ■ 0.2 to 1.0 bar / 3 to 15 psig or ■ 0.4 to 2.0 bar / 6 to 30 psig pneumatic pressure signal</p> <p>Differential Gap Controllers:</p> <p>■ 0 and 1.4 bar / 0 and 20 psig or</p> <p>■ 0 and 2.4 bar / 0 and 35 psig pneumatic pressure signal</p> <p>Action: Control action is field reversible between ■ direct (increasing sensed pressure produces increasing output signal) and ■ reverse (increasing sensed pressure produces decreasing output signal).</p>	<p>For Proportional-Only Controllers: Full output pressure change adjustable from ■ 2% to 100% of the sensing element range for 0.2 to 1.0 bar / 3 to 15 psig or ■ 4% to 100% of the sensing element range for 0.4 to 2.0 bar / 6 to 30 psig</p> <p>For Proportional-Plus-Reset Controllers: Full output pressure change adjustable from ■ 3% to 100% of the sensing element range for 0.2 to 1.0 bar / 3 to 15 psig or ■ 6% to 100% of the sensing element range for 0.4 to 2.0 bar / 6 to 30 psig</p>
Supply Pressure Requirements ⁽¹⁾	Differential Gap Adjustment
See Table 5	<p>For Differential Gap Controllers: Full output pressure change adjustable from 15% to 100% of sensing element range</p>
Supply Pressure Medium	Reset Adjustment
<p>Air or Natural Gas</p> <p>Supply medium must be clean, dry and noncorrosive and meet the requirements of ISA Standard 7.0.01 or ISO 8573-1.</p> <p>A maximum 40 micrometer particle size in the air system is acceptable. Further filtration down to 5 micrometer particle size is recommended. Lubricant content is not to exceed 1 ppm weight (w/w) or volume (v/v) basis. Condensation in the air supply should be minimized</p>	<p>For Proportional-Plus-Reset Controllers: Adjustable from 0.01 to 74 minutes per repeat (100 to 0.01 repeats per minute)</p>
Steady-State Air Consumption ⁽²⁾⁽³⁾	Zero Adjustment (Transmitters Only)
<p>0.2 to 1.0 bar / 3 to 15 psig: 0.08 normal m³/hour / 3 scfh</p> <p>0.4 to 2.0 bar / 6 to 30 psig: 0.12 normal m³/hour / 4.5 scfh</p>	Continuously adjustable to position span of less than 100% anywhere within the sensing element range

- continued -

Table 1. Specifications (continued)





Span Adjustment (Transmitters Only)	Housing
Full output pressure change adjustable from 6 to 100% of process sensing element range	Designed to NEMA 3 (Weatherproof) and IEC 529 IP54 Specifications
Performance	Hazardous Area Classification
<p>Repeatability: 0.5% of sensing element range</p> <p>Dead Band (Except Differential Gap Controllers⁽⁴⁾): 0.1% of sensing element range</p> <p>Typical Frequency Response at 100% Proportional Band:</p> <p>Output to Actuator: 0.7 Hz and 110 degree phase shift with 1850 cm³ / 113 in³ volume actuator at mid-stroke</p> <p>Output to Positioner Bellows: 9 Hz and 130 degree phase shift with 0.2 to 1.0 bar / 3 to 15 psig output to 33 cm³ / 2 in³ bellows</p>	<p>Complies with the requirements of ATEX Group II Category 2 Gas and Dust</p> <p>  II 2 G D Ex h IIC Tx Gb Ex h IIIC Tx Db</p> <p>Maximum surface temperature (Tx) depends on operating conditions</p> <p>Gas: T4, T5, T6 Dust: T85 to T104</p>
Ambient Operating Temperature Limits ⁽¹⁾	<p>Meets Customs Union technical regulation TP TC 012/2011 for Groups II/III Category 2 equipment</p> <p> II Gb c T*X  III Db c T*X</p>
<p>■ Standard Construction: -40 to 71°C / -40 to 160°F</p> <p>■ High Temperature Construction: -18 to 104°C / 0 to 220°F</p> <p>Anti-reset windup (differential pressure relief) and process pressure gauge options are only available in the standard construction</p>	
Typical Ambient Temperature Operating Influence	Construction Materials
<p>Proportional Control only: ±3.0% of output span for each 28°C / 50°F change in temperature between -40 and 71°C / -40 and 160°F for a controller set at 100% proportional band</p> <p>Reset Control only: ±2.0% of output span for each 28°C / 50°F change in temperature between -40 and 71°C / -40 and 160°F for a controller set at 100% proportional band</p> <p>Transmitters only: ±3.0% of output span for each 28°C / 50°F change in temperature between -40 and 71°C / -40 and 160°F for a transmitter set at 100% span</p>	<p>See Tables 3, 4 and 7</p>
	Approximate Weight
	8.2 kg / 18 lbs
<p>NOTE: Specialized instrument terms are defined in ANSI/ISA Standard 51.1 - Process Instrument Terminology.</p> <p>1. The pressure and temperature limits in this document and any applicable standard or code limitation should not be exceeded.</p> <p>2. Normal m³/hr: normal cubic meters per hour (m³/hr, 0°C and 1.01325 bar, absolute). Scfh: standard cubic feet per hour (ft³/hr, 60°F and 14.7 psig).</p> <p>3. To convert from air flow rate to natural gas flow rate multiply by 1.29.</p> <p>4. An adjustable differential gap (differential gap controllers) is equivalent to an adjustable deadband.</p>	

Table 2. Available Configurations

DESCRIPTION ⁽¹⁾		AVAILABLE CONFIGURATIONS		
		Pressure		
		Bourdon Tube Sensing Element (Gauge Pressure Only)	Bellows Sensing Element	
Gauge Pressure	Differential Pressure			
Proportional controller		C1P	C1B	C1D
Proportional-plus-reset controller	Without anti-reset windup			---
	With anti-reset windup			---
Differential-gap controller				---
Transmitter				C1D

1. See Figures 5 and 6 for construction details.

Table 3. Bourdon Tube Pressure Ranges and Materials

PRESSURE RANGES ⁽¹⁾		MAXIMUM ALLOWABLE STATIC PRESSURE LIMITS ⁽²⁾				MATERIAL ⁽⁴⁾
		Standard		With Optional Travel Stop ⁽³⁾		
bar	psig	bar	psig	bar	psig	
0 to 2.0	0 to 30	2.0	30	3.3	48	316 Stainless Steel
0 to 4.0	0 to 60	4.0	60	6.6	96	
0 to 7.0	0 to 100	7.0	100	11	160	
0 to 14	0 to 200	14	200	19	280	
0 to 20	0 to 300	20	300	29	420	
0 to 40	0 to 600	40	600	50	720	
0 to 70	0 to 1000	70	1000	83	1200	
0 to 100	0 to 1500	100	1500	115	1650	
0 to 200	0 to 3000	200	3000	230	3300	
0 to 350	0 to 5000	350	5000	380	5500	
0 to 550	0 to 8000	550	8000	550	8000	
0 to 700	0 to 10,000	700	10,000	700	10,000	

1. Range marked on Bourdon tube may be in kPa (1 bar = 100 kPa).
 2. Bourdon tube may be pressured to limit shown without permanent zero shift.
 3. With travel stop set at 110% of the range.
 4. Bourdon tubes are also available in NACE compliant material. Contact your [Emerson sales office](#) for additional information.

Table 4. Bellows Pressure Ranges and Materials

PRESSURE RANGES			MAXIMUM ALLOWABLE STATIC PRESSURE LIMITS ⁽¹⁾				
			Brass Construction		Stainless Steel Construction		
			bar	psig	bar	psig	
Gauge pressure	Vacuum	0 to 150 mbar / 0 to 60 in. wc	1.4	20	---	--	
		0 to 340 mbar / 0 to 10 in. Hg	2.8	40	---	---	
		0 to 1.0 bar / 0 to 30 in. Hg	2.8	40	6.9	100	
	Compound pressure	- 75 mbar to 75 mbar / - 30 in. wc to 30 in. wc		-0.07	-1	---	---
		- 500 mbar to 500 mbar / - 15 in. Hg to 7.5 psig		2.8	40	6.9	100
		- 1.0 bar to 1.0 bar / - 30 in Hg to 15 psig		2.8	40	6.9	100
	Positive pressure	0 to 150 mbar / 0 to 60 in. wc		1.4	20	---	---
		0 to 250 mbar ⁽²⁾ / 0 to 100 in. wc		1.4	20	---	---
		0 to 350 mbar ⁽³⁾ / 0 to 140 in. wc		2.8	40	---	---
		0 to 0.35 bar / 0 to 5 psig		2.8	40	---	---
0 to 0.5 bar / 0 to 7.5 psig		2.8	40	---	---		
0 to 0.7 bar / 0 to 10 psig		2.8	40	---	---		
Differential pressure ⁽⁴⁾	0 to 200 mbar / 0 to 80 in. wc		1.4	20	---	---	
	0 to 0.7 bar / 0 to 10 psi		2.8	40	---	---	
	0 to 1.4 bar / 0 to 20 psi		2.8	40	---	---	
	0 to 2.0 bar / 0 to 30 psi		---	---	6.9	100	

1. Bellows may be pressured to limit shown without permanent zero shift.
 2. C1B transmitter only.
 3. Except C1B transmitter.
 4. The overrange limit for these sensing elements is a differential pressure equal to the maximum allowable static pressure limit.

Table 5. Supply Pressure Data

Output Signal		Normal Operating Supply Pressure ⁽¹⁾	Maximum Allowable Supply Pressure To Prevent Internal Part Damage ⁽²⁾
bar	0.2 to 1.0 or 0 and 1.4 (differential gap)	1.4	2.8
	0.4 to 2.0 or 0 and 2.4 (differential gap)	2.4	2.8
psig	3 to 15 or 0 and 20 (differential gap)	20	40
	6 to 30 or 0 and 35 (differential gap)	35	40

1. If this pressure is exceeded, control may be impaired.
 2. If this pressure is exceeded, damage to the controller may result.

Table 6. Supply and Output Pressure Gauge Ranges

Gauge Scale	0.2 to 1.0 bar / 3 to 15 psig or 0 and 1.4 bar / 0 and 20 psig Output	0.4 to 2.0 bar / 6 to 30 psig or 0 and 2.4 bar / 0 and 35 psig Output
Single	0 to 30 psig 0 to 2 kg/cm ² 0 to 200 kPa	0 to 60 psig 0 to 4 kg/cm ² 0 to 400 kPa
Dual	0 to 30 psig / 0 to 200 kPa	0 to 60 psig / 0 to 400 kPa
Triple	0 to 30 psig / 0 to 2 kg/cm ² / 0 to 2 bar	0 to 60 psig / 0 to 4 kg/cm ² / 0 to 4 bar

Table 7. Construction Materials

	Part	Material
In contact with process	Bourdon tube	Stainless steel or NACE compliant N04400 Nickel alloy ⁽¹⁾
	Sensing bellows	Brass or Stainless steel
	Pressure block	Stainless steel or NACE compliant Stainless steel ⁽¹⁾
	Control tubing (from pressure block to sensing element and to optional process pressure gauge)	Stainless steel or NACE compliant Stainless steel ⁽¹⁾
In contact with operating medium	All other interior tubing	Stainless steel
	Exterior tubing	Copper (with or without PVC plastic lining), Stainless steel or Synthetic rubber
	Exterior fittings	Brass or Stainless steel
	Nozzle and reversing block	Zinc/Stainless steel
	Relay springs and spring plate	Steel
	Relay diaphragms	Nitrile/Nylon (standard) or Polyacrylate/Nylon (high-temperature)
	Other metal relay parts, proportional bellows and exhaust/reset bellows	Aluminum/Stainless steel
	Reset valve assembly and differential relief valve if used	Zinc/Steel/Ceramic
	O-rings	Nitrile (standard) or Fluorocarbon (high-temperature)
	Gaskets	Chloroprene (standard) or Silicone (high-temperature)
Other	Case and adjustment dial	Aluminum
	Cover	Aluminum, except glass for gauge windows
	Flapper	Stainless steel
	Control link	N04400 Nickel alloy and/or Stainless steel
	Flexure and pressure/ setting adjustment assemblies	Aluminum/Steel/Stainless steel/Plastic
	Calibration adjustor	Zinc
	O-rings	Nitrile
1. NACE materials compliant with the latest versions of NACE MR0175/ISO 15156 and MR0103.		

Principle of Operation

The pressure connections to the controller depend upon the type of pressure sensing, gauge or differential. Gauge pressure controllers use either a Bourdon tube or bellows as the sensing element. Differential pressure controllers use two bellows to sense differential pressure.

The key to C1 controller operation is the pressure-balanced relay with its yoked double-diaphragm assembly, shown in Figure 2 or 3.

The relay is connected so that supply pressure bleeds through the fixed orifice before escaping through the nozzle. The nozzle pressure registers on the large relay diaphragm and loading pressure (controller output) on the small relay diaphragm.

Steady-state sensed process pressure holds the Bourdon tube steady in relation to the nozzle. This allows pressure to escape between the nozzle and beam-flapper assembly at the same rate it bleeds through the orifice.

A change in the process pressure moves the beam and flapper with respect to the nozzle by either expanding or contracting the Bourdon tube arc. An increasing process pressure with direct action (or decreasing pressure with reverse action) produces a nozzle-flapper restriction that increases the loading on the large relay diaphragm. This causes the relay valve to close at the exhaust end and to open at the inlet end. Additional supply pressure flows through the relay chamber to increase the loading pressure on the control valve actuator. A decreasing process pressure with direct action (or increasing pressure with reverse action) produces a nozzle-flapper opening that bleeds off pressure on the large relay diaphragm. This causes the relay valve inlet to close and the exhaust to open, thus exhausting loading pressure from the actuator.

Figure 2. Schematic of Reverse-Acting Proportional-Only and Proportional-Plus-Reset Controllers

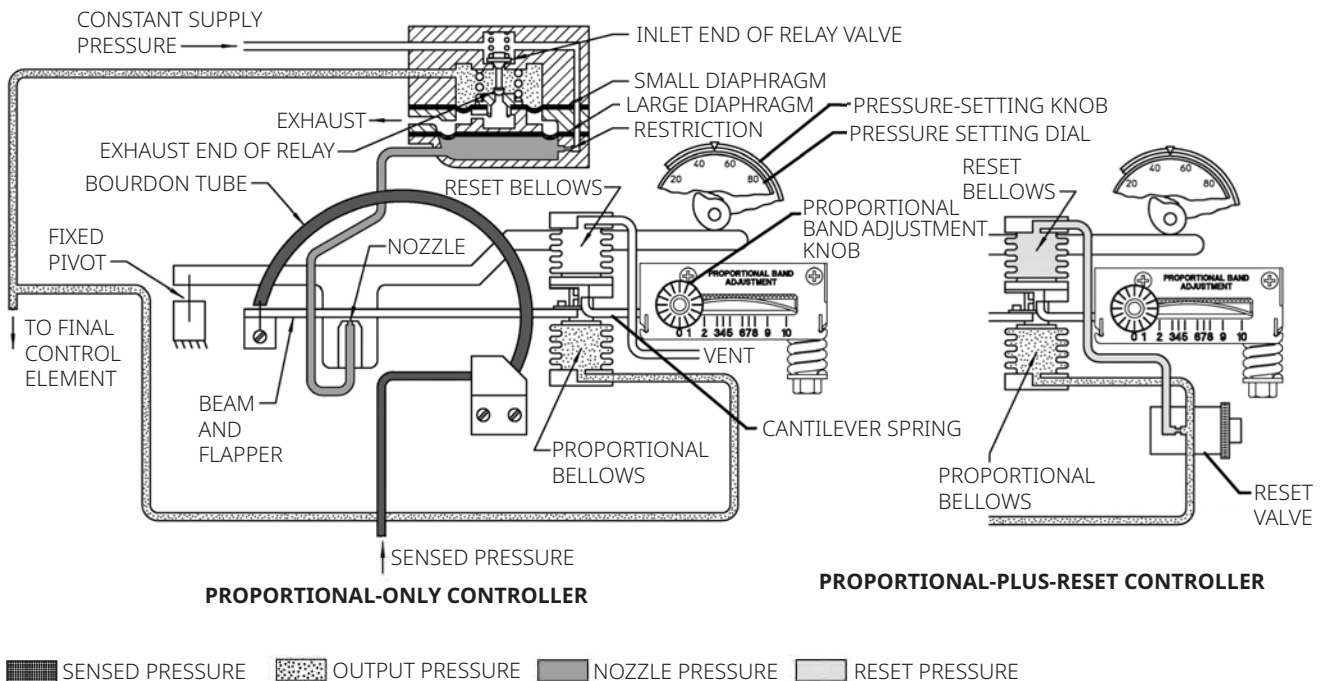

GE23696
GE34724-A
E1062

Proportional-Only Controllers

The controller output pressure change feeds back to the proportional bellows, countering the pressure change in the nozzle and equalizing the relay diaphragm pressure differential. The relay valve maintains a new loading pressure according to the change in sensed pressure.

If the proportional band adjustment is at its maximum setting, the cantilever spring in the proportional band assembly has a low spring rate, allowing more feedback motion to be transferred from the proportional bellows for a change in output pressure.

As the effective length of the cantilever is reduced, its spring rate increases, causing less feedback motion from proportional bellows. Setting the proportional band knob to its maximum results in a proportional band of 100%. The lower the proportional band adjustment, the shorter the effective length of the cantilever spring. The spring rate of the cantilever spring increases as its length shortens, allowing less motion to be transferred from the bellows to the beam and flapper for a given change in output pressure.

Figure 3. Schematic of Reverse-Acting Proportional-Plus-Reset Controller with Anti-Reset Windup

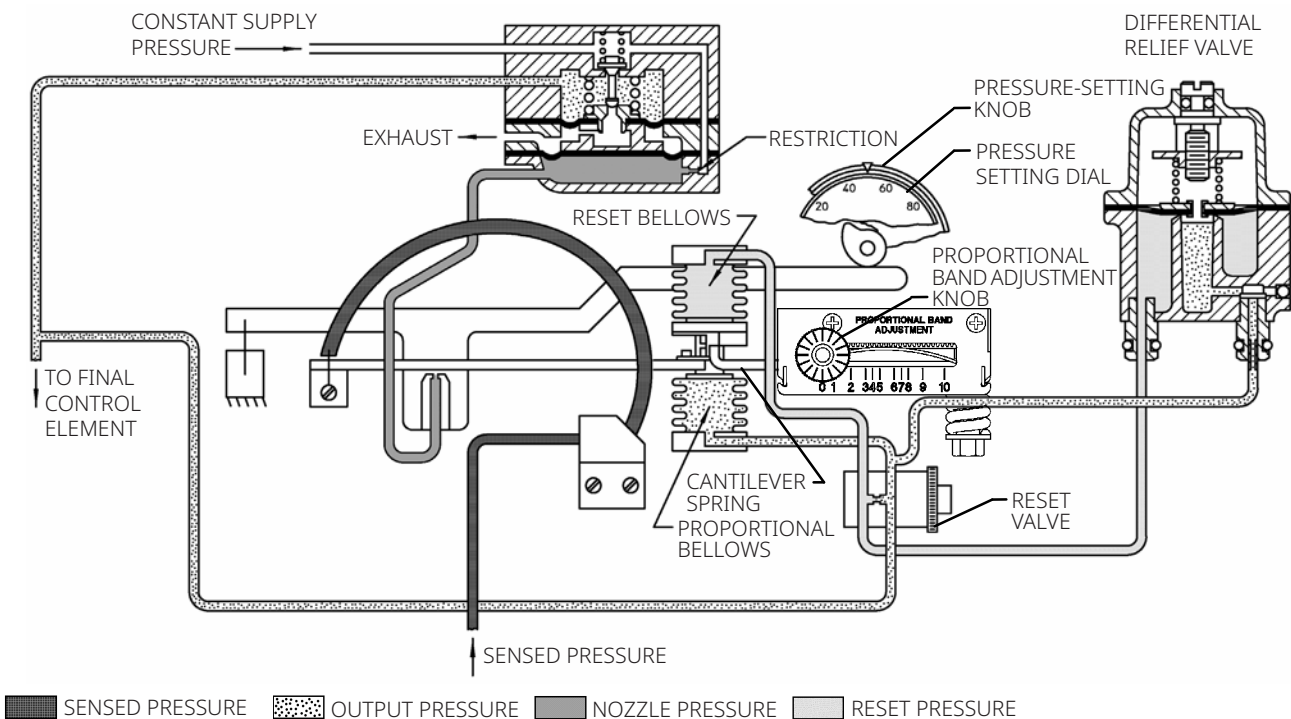

GE23697-A
 GE34724-A
 E1063-1

Proportional-Plus-Reset Controllers

Additionally, all proportional-plus-reset C1 controllers have a two-way reset restriction valve that channels proportional pressure into a reset bellows to oppose the proportional bellows action. The action of this reset pressure occurs on a delayed basis. The reset valve can be adjusted to vary the time of delay.

Anti-Reset Windup

C1 controllers with anti-reset windup have an adjustable and reversible differential relief valve to provide anti-reset windup. As shown in Figure 3, the proportional pressure registers rapidly on the spring side of the relief valve diaphragm as well as in the proportional bellows. Reset pressure registers slowly on the opposite side of the relief valve diaphragm. As long as controller output pressure changes are slow enough for normal proportional and reset action, the relief valve spring keeps the relief valve diaphragm from opening. However, a large or rapid decrease in controller output pressure causes the relay to rapidly exhaust loading pressure from the control element and also from the proportional system and spring side of the relief diaphragm. If this decrease on the spring side of the diaphragm is greater than the relief valve spring setting, the diaphragm will move off the relief valve orifice and permit the reset pressure on the opposite side of the relief valve diaphragm to bleed rapidly into the proportional system. The anti-reset windup action also can be reversed to relieve with an increasing proportional pressure.

Differential Gap Controllers

In C1 differential gap controllers, feedback pressure does not counteract the change in flapper position. Instead, the output pressure is piped to the bellows located on the side of the beam and flapper opposite the nozzle. Feedback pressure now reinforces the flapper movement by the sensed pressure change.

This construction causes the controller output to switch from full supply pressure to zero pressure or vice versa. The difference between the process pressure when the controller output switches to zero and the process pressure when the controller switches to maximum is the differential gap. Adjusting the proportional band adjustment adjusts the width of the gap; adjusting the set point positions the gap within the process pressure range.

Transmitters

Action of a pneumatic transmitter is similar to that of a proportional-only controller. Since the output pressure of the transmitter has no effect on the process pressure, transmitter output pressure is a proportional measure of the process pressure. The proportional band adjustment determines the span of the transmitter and the pressure setting mechanism determines the zero of the transmitter.

Construction Features

Rugged Service Capability

The case and cover are made of weather resistant, die-cast aluminum. Stainless steel tubing and fitting materials provide the capability for operation in ammonia and similar corrosive service conditions. Optional materials for relay diaphragms and other soft parts permit operation at ambient temperatures up to 93°C / 200°F.

Low-Pressure Precision

Bellows sensing constructions provide better accuracy in low-pressure, vacuum or compound ranges. Two sensing bellows are used where an important variable is the difference between two sensed pressures.

Conversion From Proportional To Differential Gap Control

The C1 controller can be configured to provide differential gap (on-off control) rather than proportional control. The proportional bellows is connected so that feedback pressure pushes the beam and flapper in the same direction as caused by the sensed pressure change. This reinforcement completely opens the relay valve either to full supply pressure or to full exhaust, allowing no in-between throttling. To change from a proportional to a differential gap controller or vice versa, just reverse the tubing connection on the mounting base and invert the proportional band assembly, as shown in Figure 4.

Reverse/Direct Conversion

Switching the action from reverse to direct or vice versa is done by moving the reversing block and feedback bellows connection and inverting the proportional band assembly as shown in Figure 4.

Anti-Reset Windup

The anti-reset windup capability of C1 controllers provides quick equalization of reset and proportional pressures. This capability reduces overshoot and the time required for a system to return to the pressure setting after large changes in sensed pressure. This feature is useful when slow reset and broad proportional band settings are used.

The differential relief valve has a range of 0.14 to 0.4 bar / 2 to 7 psig and, unless ordered otherwise, is set by the factory to relieve at a 0.3 bar / 5 psi difference between proportional and reset pressures.

Manual Backup

As shown in Figure 7, a Fisher 670 or 671 panel-mounted loading regulator with changeover valve permits switching to an alternate loading pressure, if a C1 controller experiences supply pressure failure or other malfunction.

Figure 4. Conversion from Reverse to Direct Action or Proportional to Differential Gap

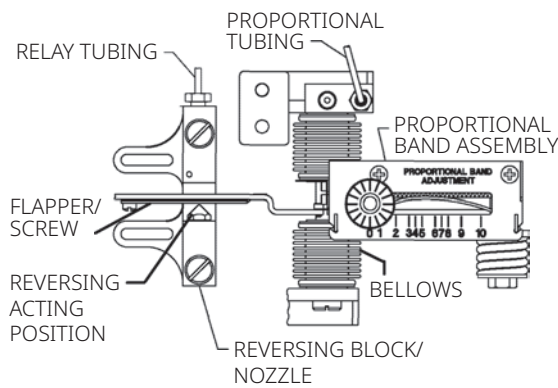

REVERSE-ACTING

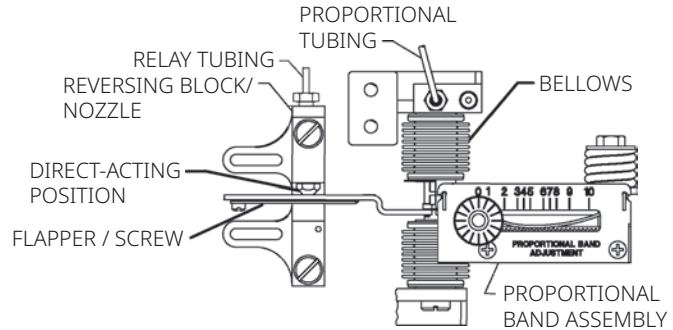

DIRECT-ACTING

GE28263-B

TO CHANGE ACTION OF THE CONTROLLER, REPOSITION THE PROPORTIONAL TUBING, REVERSING BLOCK/NOZZLE AND PROPORTIONAL BAND ASSEMBLY AS SHOWN ABOVE

PROPORTIONAL-ONLY CONTROLLER OR TRANSMITTER

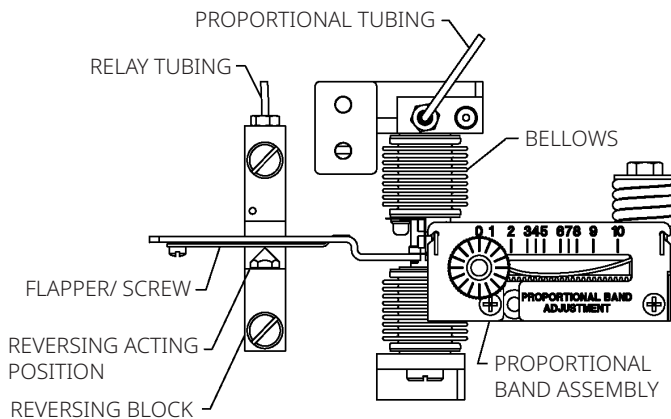

REVERSE-ACTING

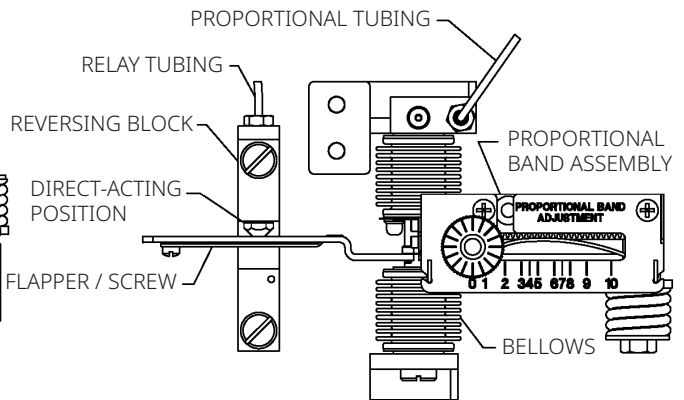

DIRECT-ACTING

GE34724-B

DIFFERENTIAL-GAP CONTROLLER

Figure 5. Fisher C1 Constructions

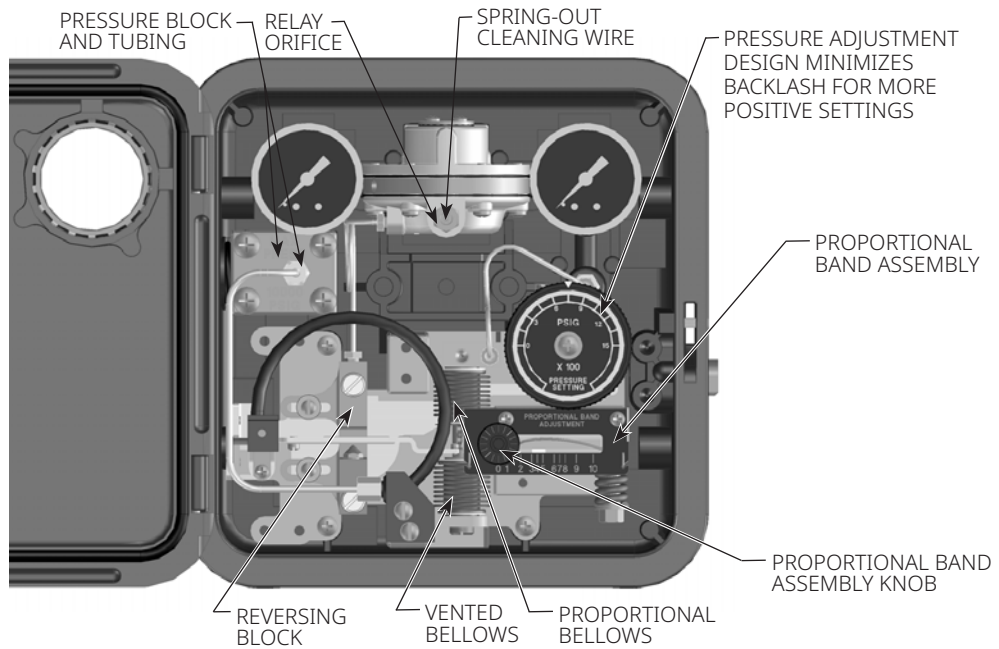

REVERSE-ACTING CONTROLLER PROPORTIONAL

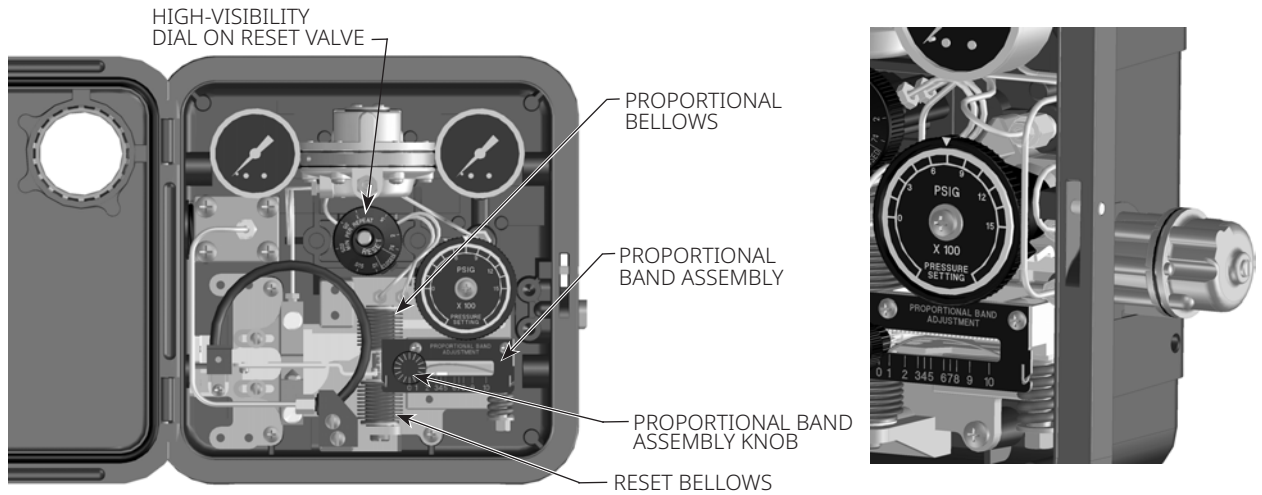

REVERSE-ACTING CONTROLLER PROPORTIONAL-PLUS-RESET

ANTI-RESET WINDUP ASSEMBLY DETAIL

GE28280-B
 GE28281-B
 GE31718-A
 E1056

Figure 6. Bellows Details

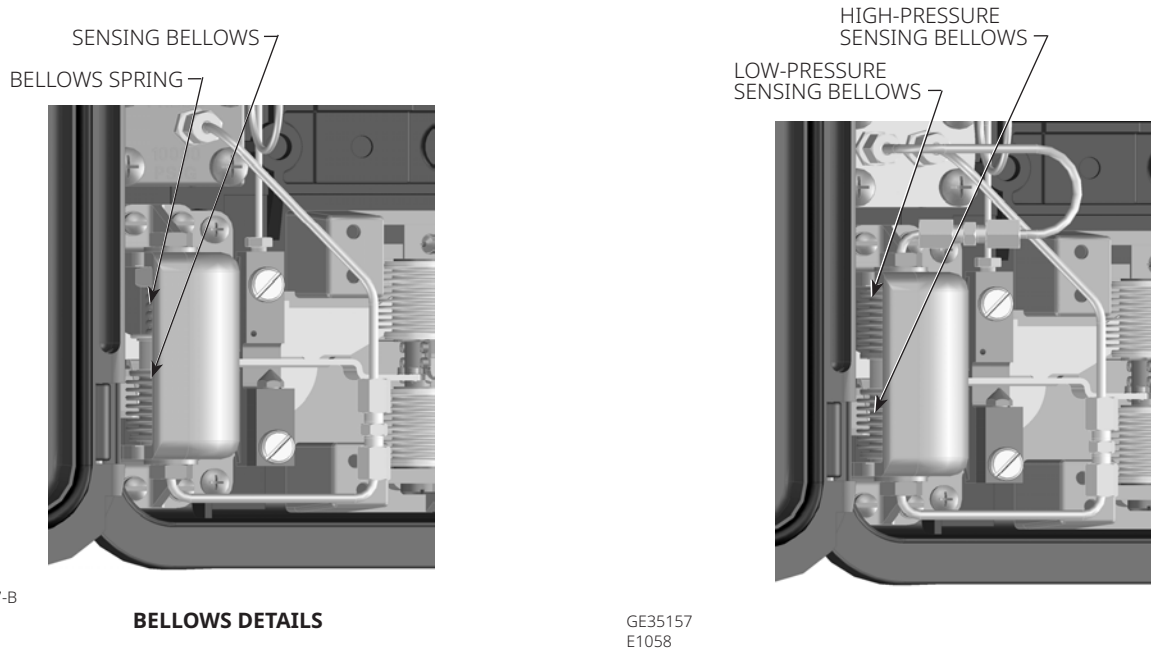
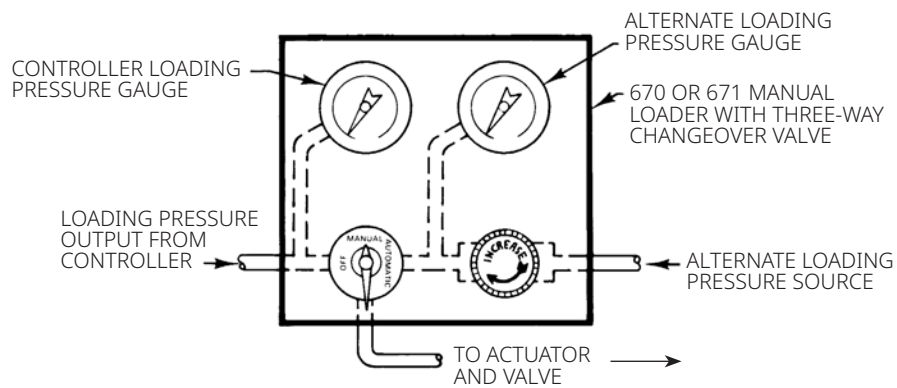

Figure 7. Schematic of Manual Backup Changeover Hookup



A2111-2

Continuous Indication of Process Pressure

Replacing the supply pressure gauge on a pressure controller or transmitter by a process pressure gauge (Figure 8) permits indicating process pressure in one of the ranges shown in Table 8. To obtain a supply pressure indication, install a gauge on the supply regulator. The process pressure gauge must be specially ordered and comes with brass trim standard in all ranges and stainless steel trim optional in some ranges. Adding a process pressure gauge in the field also requires a special control pressure block. A process pressure gauge cannot be added to controllers or transmitters that use a differential bellows for sensing pressure.

Figure 8. Process Pressure Gauge

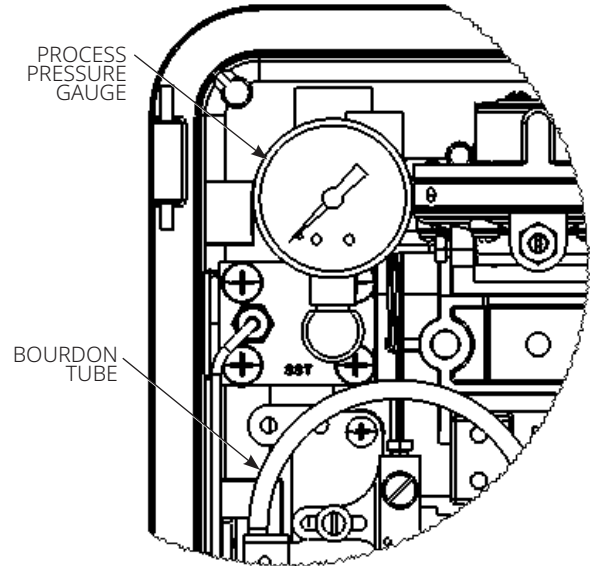

Table 8. Optional Process Pressure Gauges

Sensing Element		Gauge Range ⁽¹⁾
Bourdon tube	Positive pressure	0 to 30 psig ⁽²⁾ 0 to 60 psig 0 to 160 psig
		0 to 300 psig ⁽²⁾ 0 to 600 psig 0 to 1000 psig
Bellows	Positive pressure	0 to 30 psig ⁽²⁾

1. Consult your [Emerson sales office](#) for gauges in other units.
2. Also available in Stainless steel trim.

Bourdon Tube Protection

All Bourdon tube constructions are available with one or both of the following protective devices:

- **Barrier Protector for Corrosive or Clogging Process Fluids** — A sealed and fluid-filled barrier (described in Fisher product bulletin 39:025, [D200057X012](#)) may be installed between the process and the Bourdon tube. The barrier fluid transmits sensed pressure on a one-to-one basis into the Bourdon tube.
- **Travel Stop for Bourdon Tube** — The stop limits Bourdon tube overtravel when momentary surges in the sensed pressure exceed the Bourdon tube rating. Although it does not permit accurate control or transmission of a pressure higher than the upper range limit listed in Table 3, this stop does permit Bourdon tube overpressuring to the maximum static pressure shown in Table 3 without damage.

Installation

A C1 controller or transmitter normally comes installed on a final control element or indicating device or equipped for separate surface or pipestand mounting. Usually, a control valve with just a controller or transmitter and one supply regulator has the controller/transmitter and regulator yoke-mounted on opposite sides of the actuator as shown in Figure 9. Nipple mounting of the supply regulator (if desired) is available. Specify such mounting if the opposite yoke boss of an actuator will be occupied by a positioner.

Install the controller or transmitter so that the vent points down. Figure 10 illustrates the vent location, the location of all case connections, dimensions and mounting information.

Figure 9. Typical Yoke Mounting

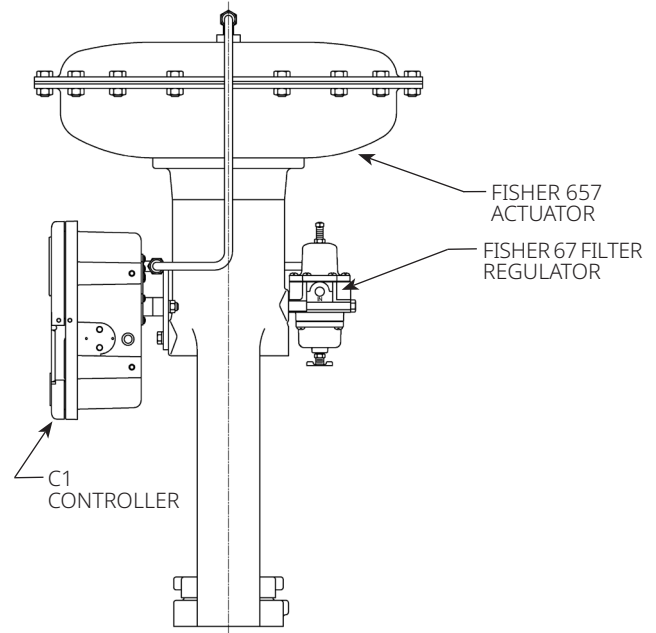

GE33947-A
E1086

Figure 10. Dimensions

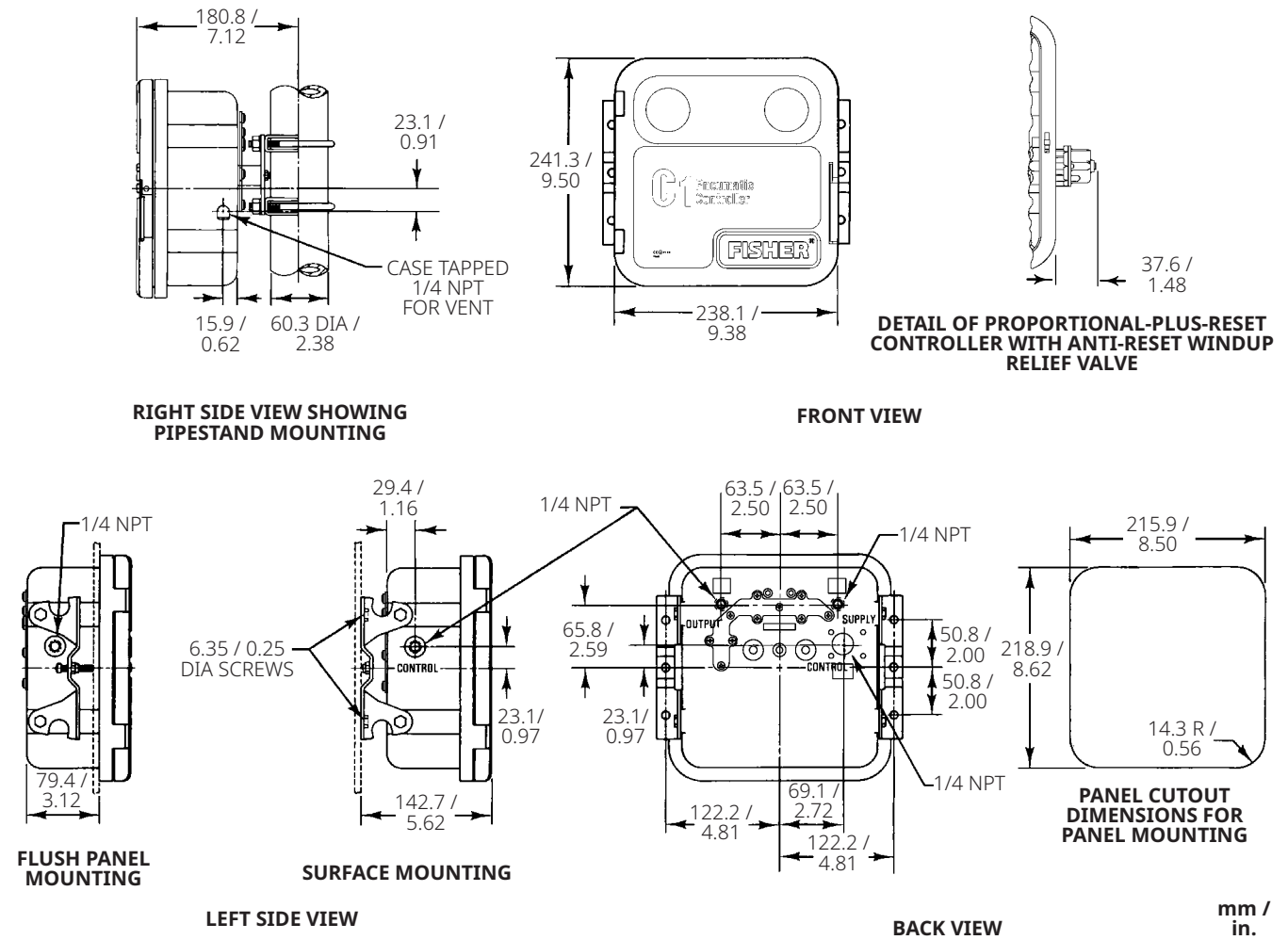

E1053

Ordering Information

Application



When ordering, specify:



1. Type of service, such as pressure reduction or pressure relief, throttling or differential gap.
2. Composition, pressure and temperature of measured variable(s).
3. Ambient temperature
4. Pressure in process vessel (if closed)
5. Type number, orientation and other applicable descriptions of control or indicating device(s).

Construction

Refer to the Specifications and the Construction Features sections. Review the description for each specification, construction feature and in the referenced tables. Specify the desired selection whenever there is a choice.

Always specify the complete type number of the C1 controller or transmitter, direct or reverse action, supply pressure regulator and other desired equipment. On controllers with anti-reset windup, specify whether the differential relief valve is to relieve with falling or rising output.

 [LinkedIn.com/groups/3941826](https://www.linkedin.com/groups/3941826)
 [Fisher.com](https://www.fisher.com)

 [Facebook.com/FisherValves](https://www.facebook.com/FisherValves)
 [X.com/FisherValves](https://www.x.com/FisherValves)

D103291X012 © 2008, 2025 Emerson. All rights reserved. The Emerson logo is a trademark and service mark of Emerson Electric Co. Fisher is a mark of an entity in the Emerson family of businesses. All other marks are the property of their respective owners.

Neither Emerson nor any of its affiliated entities assume responsibility for the selection, use or maintenance of any product. Responsibility for proper selection, use, and maintenance of any product remains solely with the purchaser and end user.

The contents of this publication are presented for informational purposes only, and while every effort has been made to ensure their accuracy, they are not to be construed as warranties or guarantees, express or implied, regarding the products or services described herein or their use or applicability. All sales are governed by our terms and conditions, which are available upon request. We reserve the right to modify or improve the designs or specifications of such products at any time without notice.

Emerson
Marshalltown, Iowa 50158 USA
Sorocaba, 18087 Brazil
Cernay, 68700 France
Dubai, United Arab Emirates
Singapore 128461 Singapore

www.fisher.com

FISHER™

EMERSON™