

Rosemount™ 5408 and 5408:SIS Level Transmitters

Non-Contacting Radar



- Unique energy-efficient two-wire FMCW radar technology for optimal performance
- Engineered and user tested for best-in-class safety, reliability, and ease-of-use
- Intuitive commissioning experience driven by wizards and adaptive graphics
- Rosemount 5408:SIS, optimal for safety applications and IEC 61508 certified to SIL 2
- Safe, easy, and remote proof testing without process interruptions
- NAMUR type tested

Introduction

Technology to redefine reliability

The Rosemount 5408 and 5408:SIS are optimized for reliable and accurate performance even in challenging process conditions. FMCW technology maximizes radar signal strength and produces a robust and reliable measurement.

The transmitters are self-powered for up to two seconds to maintain operation despite cable glitches or lightning. The minimum lift-off voltage is 9 Vdc for FOUNDATION™ Fieldbus and 12 Vdc for HART®.

Ease-of-use at every touch point

The Rosemount 5408 and 5408:SIS are designed to simplify operator tasks. They deliver ease-of-use at every touch point, from the pictorial user instructions and graphical intuitive wizards to the PTFE seal that requires no O-ring material for simplifying model selection.

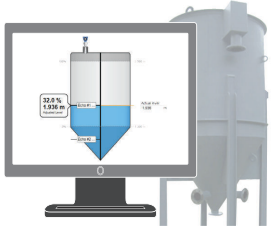

Dedicated to safety

The Smart Diagnostics Suite provides operators with early alerts in case of antenna build-up, weak power supply, or abnormal surface conditions. Also, a local memory enables full insight into the last seven days of measurements, alerts, and echo profiles.

Contents

Introduction.....	2
Ordering information.....	5
Performance specifications.....	27
Functional specifications.....	31
Physical specifications.....	45
Installation considerations.....	47
Product certifications.....	56
Dimensional drawings.....	56

The Rosemount 5408:SIS is the ideal choice for functional safety such as overfill prevention. It is safety certified (SIL 2/SIL 3), supports long proof-test intervals guaranteed to suit your schedule, and can be tested remotely without any process interruption.

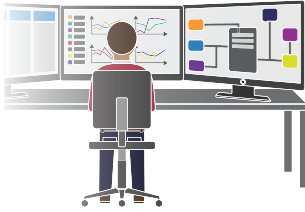

Non-contacting radar technology

Non-contacting radar technology offers a maintenance-free solution ideal for a wide range of applications. Its top-down installation minimizes leakage risks and delivers consistent performance, unaffected by factors like density, viscosity, temperature, pressure, and pH.

The device uses Frequency Modulated Continuous Wave (FMCW) technology and smart algorithms, such as Smart Echo Supervision™ technology, to maximize measurement accuracy and reliability. This ensures optimal performance, even in small tanks and challenging fast-filling vessels.

Application examples

Storage and buffer tanks

The Rosemount 5408 provides accurate and reliable level measurement for both metallic or non-metallic vessels containing almost any liquid (e.g. oil, gas condensate, water, chemicals).

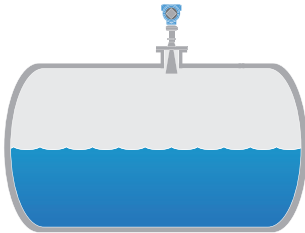

Reactors

The Rosemount 5408 is ideal for the most challenging applications, including reactors where there can be agitation, foaming, and condensation, as well as high temperatures and pressures.

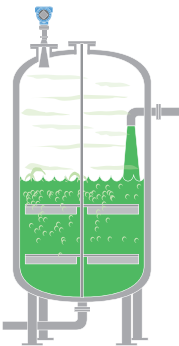

Blenders and mixers

The Rosemount 5408 can help you withstand the rigors of blenders and mixing tanks. Easy to install and commission, it is also unaffected by virtually any fluid property change.

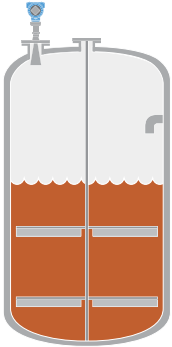

Open atmospheric applications

The Rosemount 5408 measures reliably in open applications, from short range sumps or ponds to long range dams.

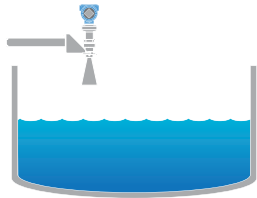

Still pipe and chamber installations

The Rosemount 5408 is a great choice for level measurement in tanks with small diameter still pipes. It may also be used in chambers, but guided wave radar is generally the best fit for these applications.

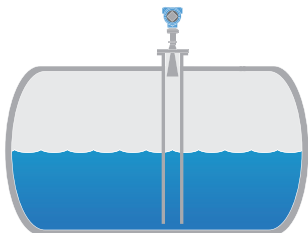

Bulk solids

The Rosemount 5408 is the ideal solution for small- to medium-sized silos with rapid level changes. The narrow beam avoids internal obstructions while still keeping good level measurement.



Safety applications

The Rosemount 5408:SIS is the ideal choice for safety functions such as overfill prevention, level deviation monitoring or dry-run prevention.

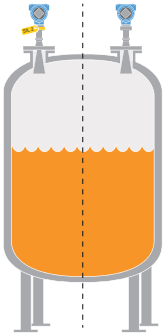

Access information when you need it with asset tags

Newly shipped devices include a unique QR code asset tag that enables you to access serialized information directly from the device. With this capability, you can:

- Access device drawings, diagrams, technical documentation, and troubleshooting information in your MyEmerson account.
- Improve mean time to repair and maintain efficiency.
- Ensure confidence that you have located the correct device.
- Eliminate the time-consuming process of locating and transcribing nameplates to view asset information.

Ordering information

Online product configurator

Many products are configurable online using our product configurator.

Select the **Configure** button or visit [Emerson.com/global](https://www.emerson.com/global) to start. With this tool's built-in logic and continuous validation, you can configure your products more quickly and accurately.

Specifications and options

Specification and selection of product materials, options, and/or components must be made by the purchaser of the equipment.

Related information

[Performance specifications](#)

[Functional specifications](#)

[Physical specifications](#)

[Material selection](#)

Model codes

Model codes contain the details related to each product. Exact model codes will vary; an example of a typical model code is shown in [Figure 1](#).

Figure 1: Model Code Example

<u>5408 F 1 S H A 1 E 5 1 R 3 A B C A B 3</u>	<u>M 5 D A 1 E F 2 Q T</u>
1	2

1. Required model components (choices available on most)
2. Additional options (variety of features and functions that may be added to products)

Optimizing lead time

The starred offerings (★) represent the most common options and should be selected for the fastest delivery. The non-starred offerings are subject to additional delivery lead time.

Rosemount 5408 Level Transmitter ordering information

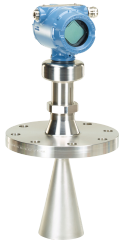

The Rosemount 5408 is a two-wire non-contacting radar transmitter for level measurements on both liquid and solid materials. It uses a unique energy efficient radar technology based on the FMCW principle to ensure reliable performance even in challenging conditions.

[CONFIGURE >](#)
[VIEW PRODUCT >](#)

Required model components

Model

Code	Description	
5408	Radar Level Transmitter	★

Profile

Code	Description	
A	Standard monitoring & control applications	★

Measurement type

Code	Description	
1	Liquid level measurement	★
3	Solids level measurement	★
4	Liquid & solids level measurement	★

Performance class

Code	Description	Reference accuracy	
A	Ultra accuracy	±0.04 in. (±1 mm)	★
S	Standard	±0.08 in. (±2 mm)	★

Signal output

Code	Description	
H	4–20 mA with HART® communication (default output from factory is HART 7, add option code HR6 for HART 6)	★
F	FOUNDATION™ Fieldbus	★
U ⁽¹⁾	Rosemount 2410 Tank Hub connectivity	★

(1) Not available with performance class code A (ultra accuracy).

Related information

[HART revision configuration](#)

Housing material

Code	Description	
A	Aluminum	★
S	Stainless steel (SST)	★

Conduit/cable threads

Code	Description	
1	½-14 NPT	★
2	M20 x 1.5	★
3 ⁽¹⁾	G½	

(1) G½ thread form is not available with hazardous locations approvals.

Hazardous locations certifications

Code	Description	
NA	None	★
E1	ATEX Flameproof	★
I1	ATEX Intrinsic Safety	★
N1	ATEX Type n	★
IA	ATEX FISCO Intrinsic Safety	★
E5	USA Explosion-proof, Dust Ignition-proof	★
I5	USA Intrinsically Safe; Nonincendive	★
IE	USA FISCO Intrinsic Safety	★
E6	Canadian Explosion-proof, Dust Ignition-proof	★
I6	Canadian Intrinsically Safe; Nonincendive	★
IF	Canadian FISCO Intrinsic Safety	★
E7	IECEX Flameproof, Dust Ignition-proof	★
I7	IECEX Intrinsic Safety	★
N7	IECEX Type n	★
IG	IECEX FISCO Intrinsic Safety	★
E2	INMETRO Flameproof	★
I2	INMETRO Intrinsic Safety	★
N2	INMETRO Type n	★
IB	INMETRO FISCO Intrinsic Safety	★
E3	China Flameproof	★
I3	China Intrinsic Safety	★
N3	China Type n	★
IC	China FISCO Intrinsic Safety	★
E4	Japan Flameproof	★
I4	Japan Intrinsic Safety	★
ID	Japan FISCO Intrinsic Safety	★

Code	Description	
EP	Republic of Korea Flameproof	★
IP	Republic of Korea Intrinsic Safety	★
EM ⁽¹⁾	Technical Regulations Customs Union (EAC) Flameproof	★
IM ⁽¹⁾	Technical Regulations Customs Union (EAC) Intrinsic Safety	★
NM ⁽¹⁾	Technical Regulations Customs Union (EAC) Type n	★
IN ⁽¹⁾	Technical Regulations Customs Union (EAC) FISCO Intrinsic Safety	★
EW	India Flameproof	★
IW	India Intrinsic Safety	★

(1) Not available with performance class code A (ultra accuracy).

Materials of construction

Code	Description	Available antenna types	
1	316/316L/EN 1.4404	Cone, parabolic	★
7	All PTFE wetted parts	Process seal	★
2	Alloy C-276 (UNS N10276) with protective plate	Cone	
3	Alloy 400 (UNS N04400) with protective plate	Cone	
H	Alloy C-276 (UNS N10276) process connection, flange, and antenna	Cone	
M	Alloy 400 (UNS N04400) process connection, flange, and antenna	Cone	

Process connection type

Code	Description	Available antenna types	
F ⁽¹⁾	Flat Face flange	Cone, parabolic	★
R ⁽²⁾	Raised Face flange	All	★
N	NPT thread	Cone	★
G	BSPP (G) thread	Cone, parabolic	★
B	Bracket mounting	All	★
C	Tri Clamp	Process seal	★
W	Welded connection	Parabolic	★
T	Ring Type Joint (RTJ) flange	Cone	

(1) Type A flat face for EN 1092-1 flanges.

(2) Type B1 raised face for EN 1092-1 flanges.

Related information

[Availability of process connections](#)

Process connection size

Code	Description	Available antenna types	
A	1½-in.	Cone	★
2	2-in./DN50/50A	Cone, process seal	★
3	3-in./DN80/80A	Cone, process seal	★

Code	Description	Available antenna types	
B	3½-in.	Parabolic	★
4	4-in./DN100/100A	Cone, process seal	★
6	6-in./DN150/150A	Cone	★
8	8-in./DN200/200A	Cone, parabolic	★
T	10-in./DN250/250A	Parabolic	★
Z	None (use when ordering bracket mounting)	All	★

Related information

[Availability of process connections](#)

Process connection rating

Code	Description		
ZZ	For use with non-flange process connection type		★
ASME flanges			
AA	ASME B16.5 Class 150		★
AB	ASME B16.5 Class 300		★
AC	ASME B16.5 Class 600		★
AD	ASME B16.5 Class 900		★
EN flanges		Note	
DK	EN1092-1 PN6		★
DA	EN1092-1 PN16	PN10 and PN16 dimensions are identical for DN50 to DN150	★
DB	EN1092-1 PN40	PN25 and PN40 dimensions are identical for DN50 to DN150	★
DC	EN1092-1 PN63		★
DD	EN1092-1 PN100		★
JIS flanges			
JK	JIS 5K		★
JA	JIS 10K		★
JB	JIS 20K		★

Related information

[Availability of process connections](#)

Antenna type

For applications where saturated steam may occur, consult factory.

Code	Description	Operating pressure	Operating temperature	
CAA	Cone antenna (PTFE seal)	-15 to 363 psig (-1 to 25 bar)	-76 to 392 °F (-60 to 200 °C)	★
CAB	Cone antenna (PTFE seal)	-15 to 725 psig (-1 to 50 bar) ⁽¹⁾	-40 to 302 °F (-40 to 150 °C)	★
CAC	Cone antenna (PTFE seal)	-15 to 1450 psig (-1 to 100 bar)	-40 to 212 °F (-40 to 100 °C)	★
CAD	Cone antenna (PTFE seal)	-15 to 44 psig (-1 to 3 bar)	-76 to 482 °F (-60 to 250 °C)	★
CBF	Cone antenna (PEEK seal, FVMQ)	-15 to 754 psig (-1 to 52 bar)	-76 to 338 °F (-60 to 170 °C)	★

Code	Description	Operating pressure	Operating temperature	
CBK	Cone antenna (PEEK seal, Kalrez® 6375)	-15 to 754 psig (-1 to 52 bar)	5 to 482 °F (-15 to 250 °C)	★
CBM	Cone antenna (PEEK seal, FKM)	-15 to 754 psig (-1 to 52 bar)	-13 to 428 °F (-25 to 220 °C)	★
CBV	Cone antenna (PEEK seal, Viton®)	-15 to 754 psig (-1 to 52 bar)	-22 to 392 °F (-30 to 200 °C)	★
SAA	Process seal antenna	-15 to 363 psig (-1 to 25 bar) ⁽²⁾	-76 to 392 °F (-60 to 200 °C) ⁽²⁾	★
PAS	Parabolic antenna, swivel mount	-7 to 43 psig (-0.5 to 3 bar)	-67 to 392 °F (-55 to 200 °C)	★

(1) Pressure limit is derated for process temperatures above 100 °F (38 °C).

(2) The final rating depends on the selected process connection.

Related information

[Process temperature and pressure rating](#)

Antenna size

Code	Description	Available antenna types	
A ⁽¹⁾	1½-in. (DN40)	Cone (PTFE seal)	★
2	2-in. (DN50)	Cone, process seal	★
3	3-in. (DN80)	Cone, process seal	★
4	4-in. (DN100)	Cone, process seal	★
8	8-in. (DN200)	Parabolic	★

(1) 1½-in. (DN40) cone antenna is available for 1½-in. NPT threaded connection and materials of construction code 1 (316/316L/EN 1.4404).

Additional options

Antenna extensions

Code	Description	Total length	Available antenna sizes	
S1	Extended cone antenna	23.6-in. (600 mm)	All except 1½-in. (DN40)	★
S2	Extended cone antenna, segmented	47.2-in. (1200 mm)		★

Purging connection

Option code PC1 is for cone antennas only, and requires matching flange and antenna sizes. Note that all parabolic antennas come with an integrated air purge connection.

A minimum gasket thickness of 0.125 in. (3.2 mm) is required for flanges with protective plate design.

Code	Description	
PC1	Purging connector (purge ring)	★

Related information

[Air purging](#)

Display

Code	Description	
M5	LCD display	★

Related information

[LCD display](#)

Diagnostic functionality

Code	Description	
DA1	HART Smart Diagnostics Suite	★
D01	FOUNDATION Fieldbus Smart Diagnostics Suite	★

Related information

[Smart Diagnostics Suite](#)

Extended measuring range

Code	Description	
ER ⁽¹⁾	Extended	★

(1) Accuracy may be reduced.

Smart proof test

The Smart Proof Test Package is included with all Rosemount 5408:SIS Level Transmitters. The package consists of multiple proof tests wizards for HART® 7. For HART 6 the package consists of only the Smart Echo Level Test.

Code	Description	
ET	Smart Proof Test Package (includes Smart Echo Level Test)	★

Related information

[Smart proof test package](#)

[Smart echo level test](#)

Smart meter verification

Smart Meter Verification (basic) is always included.

Code	Description	
MV ⁽¹⁾	Smart Meter Verification (professional)	★

(1) Includes the Smart Diagnostics Suite and Smart Proof Test Package.

Related information

[Smart meter verification](#)

HART revision configuration

Code	Description	
HR6	HART revision 6 configuration (default output from factory is HART 7, add option code HR6 for HART 6)	★

Open air applications configuration

This option is only available with parabolic antenna, 3-in. (DN80) and 4-in. (DN100) process seal antennas, and 4-in. (DN100) cone antenna.

Code	Description	
OA	Open air applications configuration; LPR (Level Probing Radar)	★

Factory configuration

Code	Description	
C1	Factory configuration per Configuration Data Sheet	★

Alarm limits

Code	Description	
C4	NAMUR alarm and saturation levels, high alarm	★
C5	NAMUR alarm and saturation levels, low alarm	★
C8 ⁽¹⁾	Standard Rosemount alarm and saturation levels, low alarm	★

(1) *The standard alarm setting is high.*

Welding standard for flanges

Only applies to flanged process connections with welded construction or protective plate design; only applicable to cone antennas.

Flanged process connections with protective plate design are only available with ASME IX (option code AW).

Code	Description	
AW	According to ASME IX	★
EW	According to EN-ISO	★

Country certification

CRN is not available with EN1092-1 or JIS B2220 flanges, neither for ASME B16.5 flanges in materials of construction code M.

Code	Description	
J1	Canadian Registration (CRN)	★

Related information

[Availability of process connections](#)

Special quality assurance

Code	Description	
Q4	Calibration data certificate	★

Hydrostatic testing

Hydrostatic testing is only available for cone antennas and process seal antennas with flanged process connections.

Code	Description	
Q5	Hydrostatic testing, including certificate	★

Material traceability certification

Certificate includes all pressure retaining and wetted parts.

Code	Description	
Q8	Material traceability certification per EN 10204 3.1 (2.1 for non-metallic)	★

Hygienic certification

Only available for process seal antennas with Tri Clamp connection.

Code	Description	
QA	Certificate of compliance to 3-A®	★

Food and Drug Administration (FDA) statement

Only available for process seal antennas with Tri Clamp connection.

Code	Description	
QH ⁽¹⁾	Certificate of compliance to FDA 21CFR110, Subpart C: Food and Drug Administration - Current Good Manufacturing Practice in Manufacturing, Packing, or Holding Human Food	★

(1) *Applicable only to wetted parts.*

Materials certification

The materials certification is not available with parabolic antenna.

For materials certification with antenna size 1½-in. (DN40), consult factory.

Code	Description	
Q15	NACE® material recommendation per NACE MR0175/ISO 15156	★
Q25	NACE material recommendation per NACE MR0103/ISO 17945	★
Q35	NACE material recommendation per NACE MR0175/ISO 15156 and NACE MR0103/ISO 17945	★

Welding procedure qualification record documentation

Only applies to flanged process connections with welded construction or protective plate design; only applicable to cone antennas.

Code	Description	
Q66	Welding Procedure Qualification Record (WPQR)	★
Q67	Welder Performance Qualification (WPQ)	★
Q68	Welding Procedure Specification (WPS)	★
Q79	WPQR/WPQ/WPS	★

Dye penetration test certificate

Only applies to flanged process connections with welded construction or protective plate design; only applicable to cone antennas.

Code	Description	
Q73	Certificate of liquid penetrant inspection	★

Positive material identification certificate

Code	Description	
Q76	Positive material identification certificate of conformance	★

Overfill prevention

Code	Description	
U1	Overfill prevention according to WHG/TUV	★

Shipboard approvals

Transmitters with aluminum housing are not approved for open deck installations; for use only in engine room, pump room, etc.

Code	Description	
SBS	American Bureau of Shipping Type Approval	★
SDN	Det Norske Veritas (DNV) Type Approval	★
SLL	Lloyd's Register Type Approval	★
SBV	Bureau Veritas Type Approval	★

Extended product warranty

Code	Description	
WR3	3-year limited warranty	★
WR5	5-year limited warranty	★
WRA	10-year limited warranty	★

Conduit electrical connector (shipped uninstalled)

Requires ½-14 NPT conduit/cable threads. Available with Intrinsically Safe approvals only.

Code	Description	
EC	M 12, 4-pin, male connector (eurofast®)	★
MC	A size Mini, 4-pin, male connector (minifast®)	★

Specials

Code	Description	
PXXXX	Custom engineered solutions beyond standard model codes. Consult factory for details.	

Related information

[Engineered solutions](#)

Rosemount 5408:SIS Level Transmitter ordering information



Safety certified to IEC 61508 for SIL2 applications with SIL3 capability, the Rosemount 5408:SIS reduces cost of risk, increases efficiency, and protects your staff and the environment.

[CONFIGURE >](#)
[VIEW PRODUCT >](#)

Required model components

Model

Code	Description	
5408	Radar Level Transmitter	★

Profile

Code	Description	
F ⁽¹⁾	Functional safety / SIS applications	★

(1) *The Rosemount 5408:SIS has two operational modes: Safety (SIS) and Control/Monitoring. Safety (SIS) mode must be set when used in Safety Instrumented Systems. Control/Monitoring mode is intended for use in a Basic Process Control System (BPCS).*

Measurement type

Code	Description	
1	Liquid level measurement	★
3	Solids level measurement	★
4	Liquid & solids level measurement	★

Performance class

Code	Description	Reference accuracy	
A	Ultra accuracy	±0.04 in. (±1 mm)	★
S	Standard	±0.08 in. (±2 mm)	★

Signal output

Code	Description	
H	4–20 mA with HART [®] communication (default output from factory is HART 7, add option code HR6 for HART 6)	★

Related information

[HART revision configuration](#)

Housing material

Code	Description	
A	Aluminum	★
S	Stainless steel (SST)	★

Conduit/cable threads

Code	Description	
1	½-14 NPT	★
2	M20 x 1.5	★
3 ⁽¹⁾	G½	

(1) G½ thread form is not available with hazardous locations approvals.

Hazardous locations certifications

Code	Description	
NA	None	★
E1	ATEX Flameproof	★
I1	ATEX Intrinsic Safety	★
N1	ATEX Type n	★
E5	USA Explosion-proof, Dust Ignition-proof	★
I5	USA Intrinsically Safe; Nonincendive	★
E6	Canadian Explosion-proof, Dust Ignition-proof	★
I6	Canadian Intrinsically Safe; Nonincendive	★
E7	IECEX Flameproof, Dust Ignition-proof	★
I7	IECEX Intrinsic Safety	★
N7	IECEX Type n	★
E2	INMETRO Flameproof	★
I2	INMETRO Intrinsic Safety	★
N2	INMETRO Type n	★
E3	China Flameproof	★
I3	China Intrinsic Safety	★
N3	China Type n	★
E4	Japan Flameproof	★
I4	Japan Intrinsic Safety	★
EP	Republic of Korea Flameproof	★
IP	Republic of Korea Intrinsic Safety	★
EM ⁽¹⁾	Technical Regulations Customs Union (EAC) Flameproof	★
IM ⁽¹⁾	Technical Regulations Customs Union (EAC) Intrinsic Safety	★
NM ⁽¹⁾	Technical Regulations Customs Union (EAC) Type n	★

Code	Description	
EW	India Flameproof	★
IW	India Intrinsic Safety	★

(1) Not available with performance class code A (ultra accuracy).

Materials of construction

Code	Description	Available antenna types	
1	316/316L/EN 1.4404	Cone, parabolic	★
7	All PTFE wetted parts	Process seal	★
2	Alloy C-276 (UNS N10276) with protective plate	Cone	
3	Alloy 400 (UNS N04400) with protective plate	Cone	
H	Alloy C-276 (UNS N10276) process connection, flange, and antenna	Cone	
M	Alloy 400 (UNS N04400) process connection, flange, and antenna	Cone	

Process connection type

Code	Description	Available antenna types	
F ⁽¹⁾	Flat Face flange	Cone, parabolic	★
R ⁽²⁾	Raised Face flange	All	★
N	NPT thread	Cone	★
G	BSPP (G) thread	Cone, parabolic	★
C	Tri Clamp	Process seal	★
W	Welded connection	Parabolic	★
T	Ring Type Joint (RTJ) flange	Cone	

(1) Type A flat face for EN 1092-1 flanges.

(2) Type B1 raised face for EN 1092-1 flanges.

Related information

[Availability of process connections](#)

Process connection size

Code	Description	Available antenna types	
A	1½-in.	Cone	★
2	2-in./DN50/50A	Cone, process seal	★
3	3-in./DN80/80A	Cone, process seal	★
B	3½-in.	Parabolic	★
4	4-in./DN100/100A	Cone, process seal	★
6	6-in./DN150/150A	Cone	★
8	8-in./DN200/200A	Cone, parabolic	★
T	10-in./DN250/250A	Parabolic	★

Related information

[Availability of process connections](#)

Process connection rating

Code	Description	
ZZ	For use with non-flange process connection type	★
ASME flanges		
AA	ASME B16.5 Class 150	★
AB	ASME B16.5 Class 300	★
AC	ASME B16.5 Class 600	★
AD	ASME B16.5 Class 900	★
EN flanges		Note
DK	EN1092-1 PN6	★
DA	EN1092-1 PN16	PN10 and PN16 dimensions are identical for DN50 to DN150
DB	EN1092-1 PN40	PN25 and PN40 dimensions are identical for DN50 to DN150
DC	EN1092-1 PN63	★
DD	EN1092-1 PN100	★
JIS flanges		
JK	JIS 5K	★
JA	JIS 10K	★
JB	JIS 20K	★

Related information

[Availability of process connections](#)

Antenna type

For applications where saturated steam may occur, consult factory.

Code	Description	Operating pressure	Operating temperature	
CAA	Cone antenna (PTFE seal)	-15 to 363 psig (-1 to 25 bar)	-76 to 392 °F (-60 to 200 °C)	★
CAB	Cone antenna (PTFE seal)	-15 to 725 psig (-1 to 50 bar) ⁽¹⁾	-40 to 302 °F (-40 to 150 °C)	★
CAC	Cone antenna (PTFE seal)	-15 to 1450 psig (-1 to 100 bar)	-40 to 212 °F (-40 to 100 °C)	★
CAD	Cone antenna (PTFE seal)	-15 to 44 psig (-1 to 3 bar)	-76 to 482 °F (-60 to 250 °C)	★
CBF	Cone antenna (PEEK seal, FVMQ)	-15 to 754 psig (-1 to 52 bar)	-76 to 338 °F (-60 to 170 °C)	★
CBK	Cone antenna (PEEK seal, Kalrez [®] 6375)	-15 to 754 psig (-1 to 52 bar)	5 to 482 °F (-15 to 250 °C)	★
CBM	Cone antenna (PEEK seal, FKM)	-15 to 754 psig (-1 to 52 bar)	-13 to 428 °F (-25 to 220 °C)	★
CBV	Cone antenna (PEEK seal, Viton [®])	-15 to 754 psig (-1 to 52 bar)	-22 to 392 °F (-30 to 200 °C)	★
SAA	Process seal antenna	-15 to 363 psig (-1 to 25 bar) ⁽²⁾	-76 to 392 °F (-60 to 200 °C) ⁽²⁾	★
PAS	Parabolic antenna, swivel mount	-7 to 43 psig (-0.5 to 3 bar)	-67 to 392 °F (-55 to 200 °C)	★

(1) Pressure limit is derated for process temperatures above 100 °F (38 °C).

(2) The final rating depends on the selected process connection.

Related information

[Process temperature and pressure rating](#)

Antenna size

Code	Description	Available antenna types	
2	2-in. (DN50)	Cone, process seal	★
3	3-in. (DN80)	Cone, process seal	★
4	4-in. (DN100)	Cone, process seal	★
8	8-in. (DN200)	Parabolic	★

Additional options

Antenna extensions

Code	Description	Total length	Available antenna sizes	
S1	Extended cone antenna	23.6-in. (600 mm)	All except 1½-in. (DN40)	★
S2	Extended cone antenna, segmented	47.2-in. (1200 mm)		★

Purging connection

Option code PC1 is for cone antennas only, and requires matching flange and antenna sizes. Note that all parabolic antennas come with an integrated air purge connection.

A minimum gasket thickness of 0.125 in. (3.2 mm) is required for flanges with protective plate design.

Code	Description	
PC1	Purging connector (purge ring)	★

Related information

[Air purging](#)

Display

Code	Description	
M5	LCD display	★

Related information

[LCD display](#)

Functional safety options

Code	Description	
EF2	Extended SIS package (transmitter's measurement response time calculator)	★

Diagnostic functionality

Code	Description	
DA1	HART Smart Diagnostics Suite	★

Related information

[Smart Diagnostics Suite](#)

Smart meter verification

Smart Meter Verification (basic) is always included.

Code	Description	
MV ⁽¹⁾	Smart Meter Verification (professional)	★

(1) Includes the Smart Diagnostics Suite.

Related information

[Smart meter verification](#)

HART revision configuration

Code	Description	
HR6	HART revision 6 configuration (default output from factory is HART 7, add option code HR6 for HART 6)	★

Open air applications configuration

This option is only available with parabolic antenna, 3-in. (DN80) and 4-in. (DN100) process seal antennas, and 4-in. (DN100) cone antenna.

Code	Description	
OA	Open air applications configuration; LPR (Level Probing Radar)	★

Factory configuration

Code	Description	
C1	Factory configuration per Configuration Data Sheet	★

Alarm limits

Code	Description	
C4	NAMUR alarm and saturation levels, high alarm	★
C5	NAMUR alarm and saturation levels, low alarm	★
C8 ⁽¹⁾	Standard Rosemount alarm and saturation levels, low alarm	★

(1) The standard alarm setting is high.

Welding standard for flanges

Only applies to flanged process connections with welded construction or protective plate design; only applicable to cone antennas.

Flanged process connections with protective plate design are only available with ASME IX (option code AW).

Code	Description	
AW	According to ASME IX	★
EW	According to EN-ISO	★

Country certification

CRN is not available with EN1092-1 or JIS B2220 flanges, neither for ASME B16.5 flanges in materials of construction code M.

Code	Description	
J1	Canadian Registration (CRN)	★

Related information

[Availability of process connections](#)

Special quality assurance

Code	Description	
Q4	Calibration data certificate	★

Hydrostatic testing

Hydrostatic testing is only available for cone antennas and process seal antennas with flanged process connections.

Code	Description	
Q5	Hydrostatic testing, including certificate	★

Material traceability certification

Certificate includes all pressure retaining and wetted parts.

Code	Description	
Q8	Material traceability certification per EN 10204 3.1 (2.1 for non-metallic)	★

Hygienic certification

Only available for process seal antennas with Tri Clamp connection.

Code	Description	
QA	Certificate of compliance to 3-A®	★

Food and Drug Administration (FDA) statement

Only available for process seal antennas with Tri Clamp connection.

Code	Description	
QH ⁽¹⁾	Certificate of compliance to FDA 21CFR110, Subpart C: Food and Drug Administration - Current Good Manufacturing Practice in Manufacturing, Packing, or Holding Human Food	★

(1) *Applicable only to wetted parts.*

Quality certification for safety

Code	Description	
QS	Certificate of FMEDA Data	★
QT	Safety-certified to IEC 61508 with certificate of FMEDA data	★

Materials certification

The materials certification is not available with parabolic antenna.

For materials certification with antenna size 1½-in. (DN40), consult factory.

Code	Description	
Q15	NACE® material recommendation per NACE MR0175/ISO 15156	★
Q25	NACE material recommendation per NACE MR0103/ISO 17945	★
Q35	NACE material recommendation per NACE MR0175/ISO 15156 and NACE MR0103/ISO 17945	★

Welding procedure qualification record documentation

Only applies to flanged process connections with welded construction or protective plate design; only applicable to cone antennas.

Code	Description	
Q66	Welding Procedure Qualification Record (WPQR)	★
Q67	Welder Performance Qualification (WPQ)	★
Q68	Welding Procedure Specification (WPS)	★
Q79	WPQR/WPQ/WPS	★

Dye penetration test certificate

Only applies to flanged process connections with welded construction or protective plate design; only applicable to cone antennas.

Code	Description	
Q73	Certificate of liquid penetrant inspection	★

Positive material identification certificate

Code	Description	
Q76	Positive material identification certificate of conformance	★

Overfill prevention

Code	Description	
U1	Overfill prevention according to WHG/TUV	★

Shipboard approvals

Transmitters with aluminum housing are not approved for open deck installations; for use only in engine room, pump room, etc.

Code	Description	
SBS	American Bureau of Shipping Type Approval	★
SDN	Det Norske Veritas (DNV) Type Approval	★
SLL	Lloyd's Register Type Approval	★
SBV	Bureau Veritas Type Approval	★

Extended product warranty

Code	Description	
WR3	3-year limited warranty	★
WR5	5-year limited warranty	★
WRA	10-year limited warranty	★

Paint option for aluminum housing

Code	Description	
PY1	Housing and covers in yellow per RAL 1003	★
PY2	Covers in yellow per RAL 1003	★
PR1	Housing and covers in red per RAL 3002	★
PR2	Covers in red per RAL 3002	★
PO1	Housing and covers in orange per Munsell 2.5 YR 6/14	★
PO2	Covers in orange per Munsell 2.5 YR 6/14	★

Conduit electrical connector (shipped uninstalled)

Requires ½-14 NPT conduit/cable threads. Available with Intrinsically Safe approvals only.

Code	Description	
EC	M 12, 4-pin, male connector (eurofast®)	★
MC	A size Mini, 4-pin, male connector (minifast®)	★

Specials

Code	Description	
PXXXX	Custom engineered solutions beyond standard model codes. Consult factory for details.	

Related information

[Engineered solutions](#)

Availability of process connections

Table 1: Cone Antenna, ASME B16.5 flanges - 316/316L SST/EN 1.4404 (Type vs. Size and Rating)

R = Raised Face; T = Ring Type Joint

Process connection size	Process connection rating, ASME B16.5 flanges			
	Class 150	Class 300	Class 600	Class 900
1½-in.	N/A	N/A	N/A	N/A
2-in.	R ⁽¹⁾	R ⁽²⁾	R ⁽²⁾ , T ⁽²⁾	R ⁽¹⁾ , T ⁽¹⁾
3-in.	R ⁽¹⁾	R ⁽²⁾	R ⁽¹⁾ , T ⁽¹⁾	R ⁽¹⁾ , T ⁽¹⁾
4-in.	R ⁽¹⁾	R ⁽¹⁾	R ⁽¹⁾ , T ⁽¹⁾	R ⁽¹⁾ , T ⁽¹⁾
6-in.	R ⁽¹⁾	R ⁽²⁾	N/A	N/A
8-in.	R ⁽²⁾	R ⁽¹⁾	N/A	N/A

(1) Forged one-piece flange.

(2) Welded construction.

Table 2: Cone Antenna, EN1092-1 flanges - 316/316L SST/EN 1.4404 (Type vs. Size and Rating)

F = Flat Face; R = Raised Face

Process connection size	Process connection rating, EN1092-1 flanges			
	PN16 ⁽¹⁾	PN40 ⁽¹⁾	PN63 ⁽²⁾	PN100 ⁽²⁾
DN50	F	F, R	F, R	F
DN80	F, R	F, R	F, R	F, R
DN100	F, R	F, R	F	F
DN150	F, R	F, R	F	N/A
DN200	F, R	F, R	N/A	N/A

(1) Welded construction for type A flat face; forged one-piece flange or welded construction for type B1 raised face.

(2) Welded construction.

Table 3: Cone Antenna, JIS B2220 flanges - 316/316L SST/EN 1.4404 (Type vs. Size and Rating)

R = Raised Face

Process connection size	Process connection rating, JIS B2220 flanges	
	10K ⁽¹⁾	20K ⁽¹⁾
50A	R	R
80A	R	R
100A	R	R
150A	R	R
200A	R	R

(1) Welded construction.

Table 4: Cone Antenna, Thread - 316/316L SST/EN 1.4404 (Type vs. Size and Rating)

G = BSPP (G) thread; N = NPT thread

Process connection size	Process connection rating, Thread
1½-in.	G, N
2-in.	G, N
3-in.	G, N
4-in.	G, N
6-in.	N/A
8-in.	N/A

Table 5: Cone Antenna - Alloy C-276 and Alloy 400 (Type vs. Size and Rating)

N = NPT thread; R = Raised Face

Process connection size	Process connection rating								
	Thread	ASME B16.5 flanges ⁽¹⁾			EN1092-1 flanges ⁽²⁾⁽⁴⁾			JIS B2220 flanges ⁽⁴⁾	
		Class 150	Class 300	Class 600	PN16	PN40	PN63	10K	20K
1½-in.	N	N/A	N/A	N/A	N/A	N/A	N/A	N/A	N/A
2-in./DN50/50A	N	R ⁽³⁾	R ⁽³⁾	R ⁽³⁾	R	R	R	R	R
3-in./DN80/80A	N/A	R ⁽³⁾	R ⁽³⁾	R ⁽⁴⁾	R	R	R	R	R
4-in./DN100/100A	N/A	R ⁽³⁾	R ⁽³⁾	N/A	R	R	R	R	R
6-in./DN150/150A	N/A	R ⁽³⁾	R ⁽⁴⁾	N/A	R	R	R	R	R
8-in./DN200/200A	N/A	R ⁽⁴⁾	N/A	N/A	R	R	N/A	R	R

- (1) Welded construction for materials of construction codes H and M.
- (2) Backing flange in flat face.
- (3) Available with materials of construction codes 2, 3, H, and M.
- (4) Only available with protective plate design (materials of construction codes 2 and 3).

Table 6: Process Seal Antenna (Type vs. Size and Rating)

C = Tri Clamp; R = Raised Face

Process connection size	Process connection rating							
	Tri Clamp	ASME B16.5 flanges ⁽¹⁾		EN1092-1 flanges ⁽¹⁾			JIS B2220 flanges ⁽¹⁾	
		Class 150	Class 300	PN6	PN16	PN40	10K	
2-in./DN50/50A	C	R	R	R	R	R	R	
3-in./DN80/80A	C	R	R	R	R	R	R	
4-in./DN100/100A	C	R	R	R	R	R	R	

- (1) Forged one-piece flange.

Table 7: Parabolic Antenna (Type vs. Size and Rating)

F = Flat Face; G = BSPP (G) thread; R = Raised Face; W = Welded connection

Process connection size	Process connection rating				
	Thread	Welded	ASME B16.5 Class 150 flange	EN1092-1 PN6 flange	JIS B2220 5K flange
3½-in.	G	W	N/A	N/A	N/A
8-in./DN200/200A	N/A	N/A	R	F	R
10-in./DN250/250A	N/A	N/A	R	F	R

Related information[Standard flanges](#)

Accessories

Flushing connection rings

Only available for process seal antennas.

Not available with Canadian Registration Number (CRN).

Item number	Description
DP0002-2111-S6	2-in. ANSI, one ¼-in. NPT connection, 316L
DP0002-3111-S6	3-in. ANSI, one ¼-in. NPT connection, 316L
DP0002-4111-S6	4-in. ANSI/DN100, one ¼-in. NPT connection, 316L
DP0002-5111-S6	DN50, one ¼-in. NPT connection, 316L
DP0002-8111-S6	DN80, one ¼-in. NPT connection, 316L

HART modem and cables

Item number	Description
03300-7004-0002	MACTek® VIATOR® HART Modem and cables (USB connection) ★

Performance specifications

General

Reference conditions

- Measurement target: Stationary metal plate, no disturbing objects
- Temperature: 59 to 77 °F (15 to 25 °C)
- Ambient pressure: 14 to 15 psi (960 to 1060 mbar)
- Relative humidity: 25-75%
- Damping: Default value, 2 s

Instrument accuracy (under reference conditions)

- Ultra accuracy: ± 0.04 in. (± 1 mm)⁽¹⁾
- Standard: ± 0.08 in. (± 2 mm)⁽¹⁾

Repeatability

± 0.04 in. (± 1 mm)

Ambient temperature effect

± 0.04 in. (± 1 mm)/10 K⁽²⁾

Sensor update rate

- 4-20 mA HART[®]: Minimum 1 update per second
- FOUNDATION[™] Fieldbus: Minimum 2 updates per second

Maximum level rate

40 mm/s as default, adjustable up to 200 mm/s

Measuring range

Table 8: Maximum Measuring Range, ft. (m)

Model	Performance class	
	Standard	Ultra accuracy
Rosemount 5408	492 (150) ⁽¹⁾	50 (15)
Rosemount 5408:SIS	130 (40)	50 (15)

(1) Up to 492 ft. (150 m) with the extended range option code ER selected, otherwise up to 130 ft. (40 m).

Note that a combination of adverse process conditions, such as heavy turbulence, foam, and condensation, together with products with poor reflection may affect the measuring range.

Measuring range for solids

The figures given in [Table 9](#) should be considered as guidelines; the total measuring range may differ depending on other contributing application conditions such as product filling, how the product piles up, silo diameter vs. angle of repose, internal obstacles within the silo, dust, condensation, antenna build up, etc.

(1) Refers to inaccuracy according to IEC 60770-1 when excluding installation dependent offset. See the IEC 60770-1 standard for a definition of radar specific performance parameters and if applicable corresponding test procedures.
 (2) Ambient temperature effect specification valid over temperature range -40 °F to 176 °F (-40 °C to 80 °C).

Table 9: Recommended Measuring Range for Solids, ft. (m)

Antenna	Light powder ⁽¹⁾	Light granulates and pellets ⁽²⁾	Heavy powder ⁽³⁾	Grains ⁽⁴⁾	Larger particles ⁽⁵⁾
1½-in. (DN40) cone ⁽⁶⁾	16 (5)	33 (10)	66 (20)	66 (20)	82 (25)
2-in. (DN50) cone/process seal ⁽⁶⁾	16 (5)	33 (10)	82 (25)	82 (25)	98 (30)
3-in. (DN80) cone/process seal ⁽⁶⁾	49 (15)	66 (20)	98 (30)	98 (30)	130 (40)
4-in. (DN100) process seal ⁽⁶⁾					
4-in. (DN100) cone ⁽⁶⁾	66 (20)	98 (30)	130 (40)	130 (40)	130 (40)
8-in. (DN200) parabolic ⁽⁷⁾	115 (35)	180 (55)	230 (70)	230 (70)	295 (90)

- (1) Light powder, etc. (Dielectric constant: 1.2)
- (2) Plastic pellets, etc. (Dielectric constant: 1.35)
- (3) Lime powder, cement, sand, etc. (Dielectric constant: 1.5)
- (4) Kernels, brans, etc. (Dielectric constant: 1.5)
- (5) Wood chips/pellets, etc. (Dielectric constant: 1.7)
- (6) Cone and process seal antennas are the preferred choice for most solid applications.
- (7) Recommended for longer measuring ranges, typically > 66 ft (20 m).

Related information

[Measuring the Level of Solid Materials Technical Note](#)

Accuracy over measuring range

Figure 2 illustrates the accuracy over measuring range at reference conditions. Actual measurement performance in the near zone and close to a strong bottom echo will depend on the product's characteristics and application conditions.

Figure 2: Accuracy Over Measuring Range

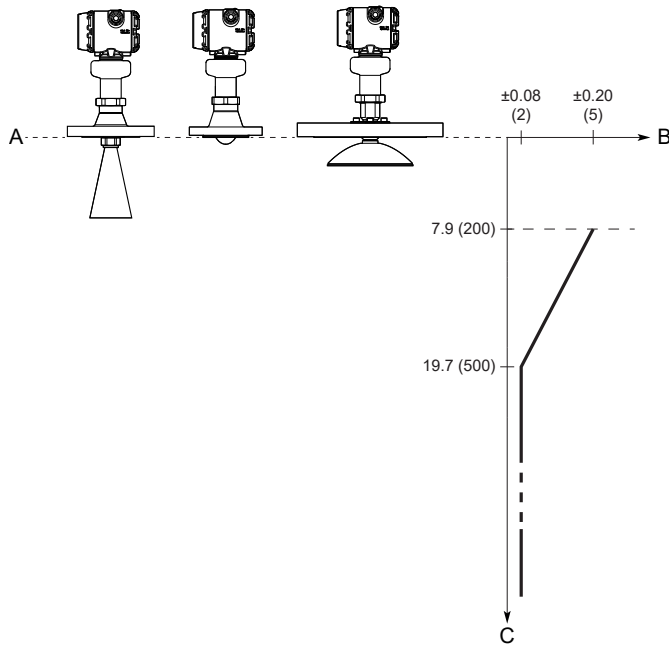

- A. Device Reference Point
- B. Accuracy in inches (millimeters)
- C. Distance in inches (millimeters)

For the extended cone antennas, the reduced accuracy zone ends 11.8 in. (30 cm) below the antenna end. The accuracy in still pipe/chamber installations depends on how well the antenna size matches the pipe size.

Related information

[Best Practices for Using Radar in Still Pipes and Chambers Technical Note](#)

Environment

Vibration resistance

- 2 g at 10-180 Hz according to IEC 61298-3, level “field with general application”
- IACS UR E10 test 7

For compliance with these standards, the transmitter housing must be fully engaged into the sensor module. This is achieved by rotating the transmitter housing clockwise to thread limit. For further details, see the Rosemount 5408 and 5408:SIS with HART® [Reference Manual](#) and Rosemount 5408 with FOUNDATION™ Fieldbus [Reference Manual](#).

Electromagnetic compatibility (EMC)

- EMC Directive (2014/30/EU): EN 61326-1
- EN 61326-2-3
- NAMUR recommendations NE21⁽³⁾

For Rosemount 5408:SIS, the blue plug on the terminal block must be connected.

Pressure Equipment Directive (PED)

Complies with 2014/68/EU article 4.3

Built-in lightning protection

EN 61326, IEC 61000-4-5, level 6kV

Radio approvals

- Radio Equipment Directive (2014/53/EU):
 - ETSI EN 302 372 (TLPR)
 - ETSI EN 302 729 (LPR)
 - EN 62479
- Part 15 of the FCC Rules
- Industry Canada RSS 211

(3) In challenging applications where the dynamic of the transmitter sensitivity is utilized by multiple factors such as small aperture antenna, very low product dielectric constant and/or turbulent surface, the margin for additional influence due to extreme EMC may be limited.

Functional specifications

General

Field of application

Continuous level measurements for tank monitoring, process control, and overfill prevention on a broad range of liquids, slurries, and solids.

Ideal for applications with varying and harsh process conditions, such as heavy turbulence, foaming, product build-up, condensing vapors, sticky, viscous, corrosive, and crystallizing products.

Measurement principle

Frequency Modulated Continuous Wave (FMCW)

Frequency range

24.05 to 27.0 (26.5⁽⁴⁾) GHz

Maximum output power

-5 dBm (0.32 mW)

Internal power consumption

< 1 W in normal operation

Humidity

0 - 100% relative humidity, non-condensing

Turn-on time

< 40 s⁽⁵⁾

Functional safety

The Rosemount 5408:SIS Level Transmitter is IEC 61508 certified to:

- Low and high demand: Type B element
- SIL 2 for random integrity @ HFT=0
- SIL 3 for random integrity @ HFT=1
- SIL 3 for systematic capability

Related information

[Functional Safety Certificate](#)

[Rosemount 5408:SIS Safety Manual](#)

(4) 26.5 GHz in Australia, New Zealand, and Russia, and for LPR (Level Probing Radar), option code OA.

(5) Time from when power is applied to the transmitter until performance is within specifications.

4-20 mA HART®

Output

Two-wire, 4-20 mA. Digital process variable is superimposed on 4-20 mA signal, and available to any host that conforms to the HART® protocol. The digital HART signal can be used in multidrop mode.

HART Revision

- Revision 6
- Revision 7

The HART revision can be switched in field.

Related information

[HART revision configuration](#)

Power supply

The transmitter operates on 12-42.4 Vdc transmitter terminal voltage (12-30 Vdc in Intrinsically Safe installations).

Power consumption

Max. 1 W, current max. 23 mA

Load limitations

For HART® communication, a minimum loop resistance of 250 Ω is required. Maximum loop resistance (R) is determined by the voltage level of the external power supply (U_E):

$$R = 43.5 \times (U_E - 12)$$

Figure 3: Load Limits

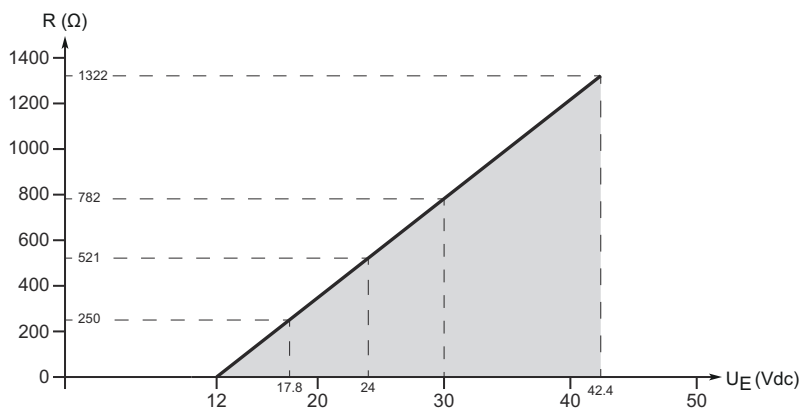

Cable selection

Use 24-14 AWG wire. Twisted pairs and shielded wiring are recommended for environments with high EMI (electromagnetic interference).

Use wire rated at least 5 °C above maximum ambient temperature.

Two wires can be safely connected to each terminal screw.

Analog signal on alarm

The transmitter automatically and continuously performs self-diagnostic routines. If a failure or a measurement error is detected, the analog signal will be driven offscale to alert the user. High or low failure mode is user-configurable.

Table 10: Signal on Alarm

Standard	High	Low
Rosemount standard	≥ 21.75 mA	≤ 3.75 mA
NAMUR NE43	≥ 22.5 mA	≤ 3.6 mA

Related information

[Alarm limits](#)

Analog saturation levels

The transmitter will continue to set a current that corresponds to the measurement until reaching the associated saturation limit (and then freeze).

Table 11: Saturation Levels

Standard	High	Low
Rosemount standard	20.8 mA	3.9 mA
NAMUR NE43	20.5 mA	3.8 mA

Related information

[Alarm limits](#)

FOUNDATION™ Fieldbus

Power supply

The transmitter operates on 9-32 Vdc (9-30 Vdc in Intrinsically Safe installations and 9-17.5 Vdc for FISCO) at the transmitter terminals.

Cable selection

Recommended wiring is 18 AWG twisted shielded pair, referred to as Fieldbus type A cable.

Use wire rated at least 5 °C above maximum ambient temperature.

Two wires can be safely connected to each terminal screw.

Quiescent current draw

22 mA

Blocks and execution time

Block	Execution time
1 Resource	N/A
2 Transducer	N/A
6 Analog Input (AI)	10 ms
1 Proportional/Integrate/Derivate (PID)	15 ms
1 Signal Characterizer (SGCR)	10 ms
1 Integrator (INT)	10 ms
1 Arithmetic (ARTH)	10 ms
1 Input Selector (ISEL)	10 ms
1 Control Selector (CS)	10 ms
1 Output Splitter (OS)	10 ms

FOUNDATION Fieldbus class (basic or Link Master)

Link Master (LAS)

Number of available VCRs

Maximum 20, including one fixed

FOUNDATION Fieldbus instantiation

Yes

Conforming FOUNDATION Fieldbus

ITK 6.3.1

FOUNDATION Fieldbus alerts

- Field diagnostics alerts
- Plantweb™ Insight alerts

Rosemount 2410 Tank Hub connectivity

Requires Rosemount 5408 with signal output code U.

Note

Rosemount 5408 Level Transmitter with signal output code F cannot be upgraded to signal output code U.

Power supply

The transmitter operates on FISCO 9.0 - 17.5 Vdc polarity insensitive (from Rosemount 2410 Tank Hub).

Cable selection

0.5-1.5 mm² (AWG 22-16), twisted shielded pairs, to be connected to the intrinsically safe side of the Rosemount 2410 Tank Hub.

Bus current draw

21 mA (nominal)

Built-in Tankbus terminator

Yes (to be connected if required)

Daisy chain possibility

Yes

Display and configuration

LCD display

- Toggles between selected output variables
- Shows diagnostic information (alerts)

Figure 4: LCD Display

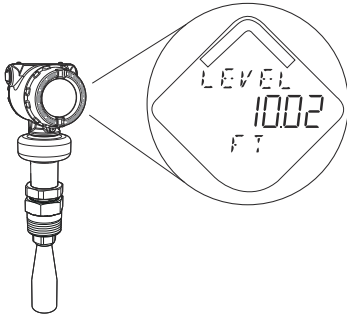

Remote display

Data can be read remotely using the Rosemount 751 Field Signal Indicator for 4-20 mA / HART®, or the Rosemount 752 Remote Indicator for FOUNDATION™ Fieldbus.

Related information

[Rosemount 751 Product Data Sheet](#)

[Rosemount 752 Product Data Sheet](#)

Configuration tools

- Field Device Integration (FDI) compliant systems
- Device Descriptor (DD) compliant systems
- Device Type Manager (DTM™) compliant systems

Related information

Emerson.com/AMSDeviceConfigurator

Rosemount Radar Master Plus

Rosemount Radar Master Plus is the recommended tool for configuration. It is a User Interface Plug-in (UIP) that includes basic configuration options, as well as advanced configuration and service functions. An FDI compliant host, such as AMS Device Configurator, or a DTM compliant host is needed to run Rosemount Radar Master Plus.

Related information

Emerson.com/RosemountRadarMasterPlus

Damping

User selectable (default is 2 s, minimum is 0 s)

Output units

- Level and distance: ft., in., m, cm, mm
- Level rate: ft/s, in./min, in./s, m/h, m/s
- Volume: ft³, in.³, yd³, US gal, imperial gal, barrel (bbl), m³, l
- Temperature: °F, °C
- Signal strength: mV

Output variables

Variable	4-20 mA ⁽¹⁾	Digital output	LCD display
Level	✓	✓	✓
Distance (ullage)	✓	✓	✓
Volume	✓	✓	✓
Scaled variable ⁽²⁾	✓	✓	✓
Electronics temperature	N/A	✓	✓
Signal quality ⁽²⁾	N/A	✓	✓
Level rate	N/A	✓	✓
Signal strength	N/A	✓	✓
Percent of range ⁽³⁾	N/A	✓	✓
Percent of range auxiliary	N/A	✓	✓
User-defined ⁽²⁾	✓	✓	✓
Loop current ⁽³⁾	N/A	N/A	✓

(1) Not applicable for FOUNDATION™ Fieldbus.

(2) Only for transmitters ordered with Smart Diagnostics Suite or Smart Meter Verification (professional).

(3) 4-20 mA HART® protocol only.

Smart Echo Supervision™ technology

The Smart Echo Supervision technology automatically tracks all echoes, including those from obstructions in the tank, and distinguishes them from the real product surface echo. This ensures the true product level is reliably and accurately reported.

Diagnostics

Alerts

The transmitter is compliant with NAMUR NE 107 Field Diagnostics for standardized device diagnostic information.

Tools and logging in Rosemount Radar Master Plus

Rosemount Radar Master Plus enables easy and powerful troubleshooting with the echo curve tool as well as the measurement and alert log.

The measurement and alert log holds records of the last seven days of level readings and echo curve profiles, as well as the 50 last alert events. The logs can be transferred from the transmitter's internal memory to a local computer and be presented in a graphical time line, enabling analysis of historical behaviors.

Smart Diagnostics Suite

Signal Quality Metrics

Diagnostics package that monitors the relations between surface, noise, and threshold. The function can be used to detect abnormal conditions in the process such as antenna contamination or sudden loss of signal strength. Signal Quality is available as output variable and it comes with user configurable alerts.

Power advisory

The transmitter automatically measures and monitors the input voltage. If the voltage is too low, operators will be provided with an early alert.

Scaled variable

The scaled variable configuration allows the user to convert a device variable into an alternative measurement, such as flow, mass, or calibrated level (e.g. five-point point verification).

User defined variable

Allows designating more than 200 variables in the device as output variable.

Proof testing solutions

Smart proof test package

Periodic proof testing is done fast and easily using the built-in wizards which will guide you through each step of the proof test. Dynamic graphics visualize the changes throughout the testing process. When you are finished, you can save or print a detailed time-stamped proof test report with pass/fail results. The last performed proof test (date, type, and result) is saved to the device and can be viewed in the UIP (Rosemount Radar Master Plus) at any time.

The Smart Proof Test Package is included with all Rosemount 5408:SIS Level Transmitters. It can also be ordered for the Rosemount 5408 by selecting option code ET or MV. The package is available with HART® 7 and it requires the use of either FDI or DTM.

Related information

[Rosemount 5408:SIS Safety Manual](#)

Smart echo level test

The function allows you to test the behavior of the transmitter in a real tank environment without raising the level. During the test, a virtual surface echo is superimposed onto the radar signal, and the transmitter will output a level corresponding to the echo position.

The test verifies the integrity of the signal processing, and can be used to test the alarm limits in the host system, output of the transmitter, and transmitter configuration (for example the upper/lower range values).

Verification

Smart meter verification

Smart Meter Verification is an automatic diagnostic tool that monitors the entire transmitter's performance and integrity without interrupting the process. The results of this diagnostic provide a pass/fail summary report helping you to quickly identify and resolve potential issues. Configuration changes since previous verification are tracked to verify consistency of the device setup.

The Smart Meter Verification functionality can be scheduled to run at defined intervals, or it can be initiated on demand. Enabling the Signal Quality Alert offers an additional layer of assurance through continuous measurement health monitoring.

Supported features

Table 12: Basic vs Professional

Feature	Basic	Professional (option code MV)
Manually initiated verification	✓	✓
Schedule verification	–	✓
Previous verifications stored	1	20
Printable report	–	✓
Continuous measurement health monitoring	(✓) ⁽¹⁾	✓

(1) Only for transmitters ordered with Smart Diagnostics Suite (includes Signal Quality Alert).

Process temperature and pressure rating

The following figures give the process temperature limits (measured at the lower part of the flange, Tri Clamp, or threaded connection) and pressure rating for different antenna types.

Final rating may be lower depending on flange selection.

For antenna type code CAB, at 100 °F (38 °C), the rating decreases with increasing temperature per ASME B16.5 Table 2-2.2, Class 300.

Note

For applications where saturated steam may occur, consult factory.

Figure 5: Cone Antenna (PTFE Seal)

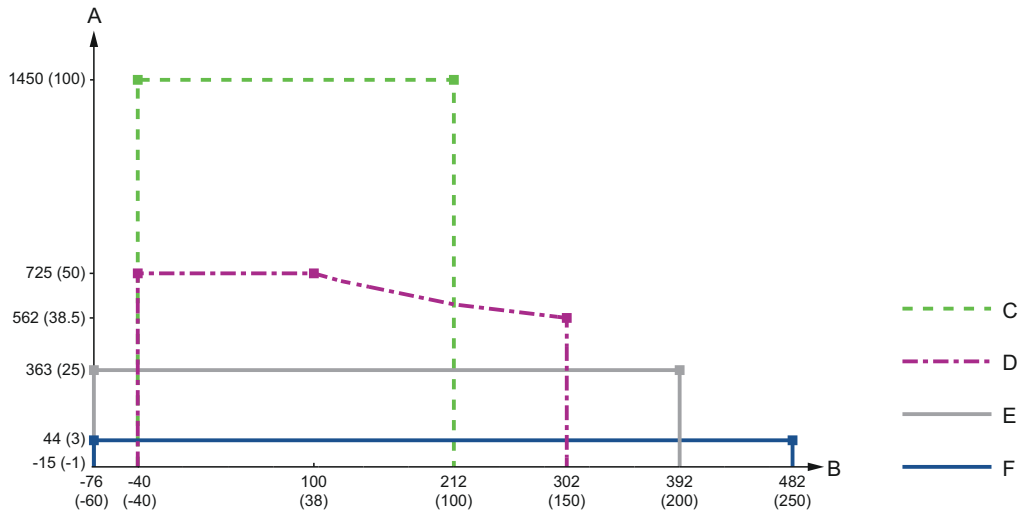

- A. Pressure psig (bar)
- B. Temperature °F (°C)
- C. Code CAC
- D. Code CAB
- E. Code CAA
- F. Code CAD

Figure 6: Cone Antenna (PEEK Seal)

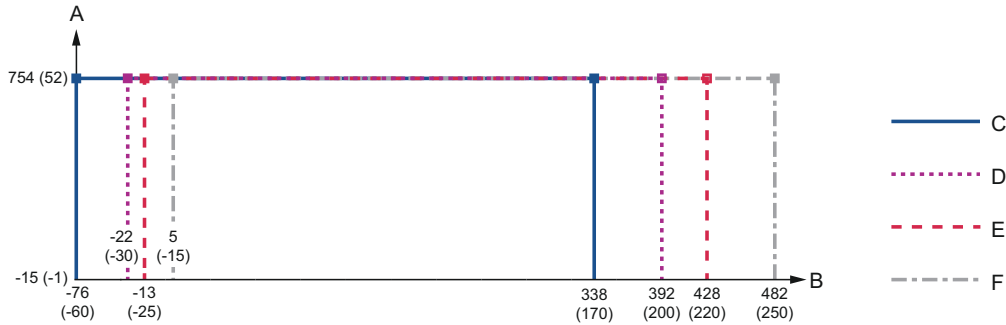

- A. Pressure psig (bar)
- B. Temperature °F (°C)
- C. Code CBF (FVMQ)
- D. Code CBV (Viton®)
- E. Code CBM (FKM)
- F. Code CBK (Kalrez® 6375)

Figure 7: Process Seal Antenna with Tri Clamp

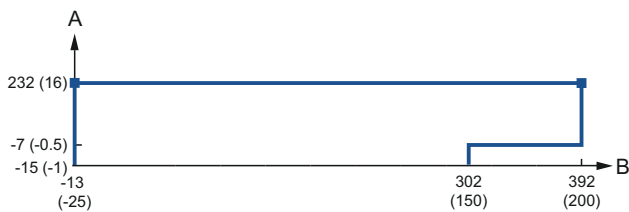

- A. Pressure psig (bar)
- B. Temperature °F (°C)

Figure 8: 2-in. Process Seal Antenna with Flange



- A. Pressure psig (bar)
- B. Temperature °F (°C)

Figure 9: 3-in. Process Seal Antenna with Flange



- A. Pressure psig (bar)
- B. Temperature °F (°C)

Figure 10: 4-in. Process Seal Antenna with Flange



- A. Pressure psig (bar)
- B. Temperature °F (°C)

Figure 11: Parabolic Antenna



- A. Pressure psig (bar)
- B. Temperature °F (°C)

Cryogenic applications

Operating temperature at flange

See [Figure 5](#) to [Figure 11](#) for antenna type specific operating limits.

Operating temperature in tank

-320.8 to 482 °F (-196 to 250 °C)

Ambient temperature limits

Table 13: Ambient Temperature Limits

Description	Operating limit	Storage limit ⁽¹⁾
Without LCD display	-40 °F to 176 °F (-40 °C to 80 °C)	-58 °F to 176 °F (-50 °C to 80 °C)
With LCD display ⁽²⁾		-40 °F to 176 °F (-40 °C to 80 °C)

(1) The minimum storage temperature is -22 °F (-30 °C) for the cone antenna with Kalrez® 6375 O-ring (antenna type code CBK).

(2) LCD display may not be readable and LCD display updates will be slower at temperatures below -4 °F (-20 °C).

The ambient temperature limits may be further restricted by the process temperature as described by [Figure 12](#).

Figure 12: Ambient Temperature vs. Process Temperature

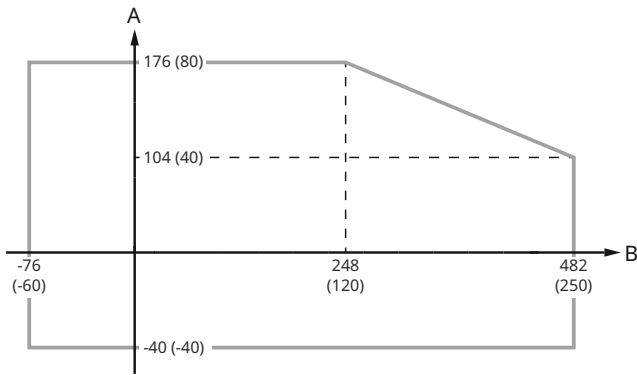

- A. Ambient temperature °F (°C)
- B. Process temperature °F (°C)

Aside from ambient temperature variations, heat from the process may be transferred to the transmitter housing. Being exposed to a high process temperature without extra cooling for an extended period of time may cause the electronics temperature to exceed the allowed limit and thereby affect the transmitter's performance and reliability. The latter are potential risks whenever a transmitter has shut down due to high electronics temperature. The transmitter will warn about the electronics temperature being out of limits.

Verify that the operating atmosphere of the transmitter is consistent with the appropriate hazardous locations certifications.

Related information

[Product certifications](#)

Flange rating

ASME

- 316 SST according to ASME B16.5 Table 2-2.2
- 316L SST according to ASME B16.5 Table 2-2.3 (for protective plate design)⁽⁶⁾
- Alloy C-276 (UNS N10276) according to ASME B16.5 Table 2-3.8
- Alloy 400 (UNS N04400) according to ASME B16.5 Table 2-3.4

EN

- 1.4404 according to EN 1092-1 material group 13E0
- Alloy C-276 (UNS N10276) according to EN 1092-1 material group 12E0

JIS

- 316 SST according to JIS B2220 material group No. 2.2
- 316L SST according to JIS B2220 material group No. 2.3 (for protective plate design)⁽⁶⁾

Conditions used for flange strength calculations

Table 14: Stainless Steel Flanges

Item	ASME	EN, JIS
Bolting material	SA193 B8M CL.2, SA193 B7 ⁽¹⁾ , or SA320 L7 ⁽¹⁾	ISO 3506 A4-70 or Bumax [®] 88 ⁽¹⁾
Gasket ⁽²⁾	Soft (1a) with min. thickness 1.6 mm or Spiral wound gasket with nonmetallic filler (1b)	Soft (EN 1514-1) with min. thickness 1.6 mm or Spiral wound gasket with nonmetallic filler (EN 1514-2)
Flange material	Stainless steel A182 Gr. F316 and EN 10222-5-1.4404	
Hub material ⁽³⁾	Stainless steel SA479 316 and EN 10272-1.4404	

(1) Only applicable to forged one-piece flanges.

(2) Not applicable to process seal antenna (features an integrated gasket). Use of extra gasket may result in faulty installation.

(3) Only applicable to flanges with welded construction.

Table 15: Flanges with Protective Plate Design

Item	ASME	EN, JIS
Bolting material	SA193 B8M Cl.2	ISO 3506 A4-70
Gasket ⁽¹⁾	Soft (1a) with min. thickness 1.6 mm or Spiral wound gasket with nonmetallic filler (1b)	Soft (EN 1514-1) with min. thickness 1.6 mm or Spiral wound gasket with nonmetallic filler (EN 1514-2)
Flange material	Stainless steel A182 Gr. F316L/F316 and EN 10222-5-1.4404	
Hub material	SB574 Gr. N10276 (solution annealed condition) or SB164 Gr. N04400 (solution annealed condition)	

(1) Note that a minimum gasket thickness of 0.125 in. (3.2 mm) is required when using an air purge ring (option code PC1).

(6) Flange rating according to backing flange.

Table 16: Alloy C-276 (UNS N10276) Flanges

Item	ASME	EN, JIS
Bolting material	UNS N10276	UNS N10276
Gasket	Soft (1a) with min. thickness 1.6 mm or Spiral wound gasket with nonmetallic filler (1b)	Soft (EN 1514-1) with min. thickness 1.6 mm or Spiral wound gasket with nonmetallic filler (EN 1514-2)
Flange material	SB462 Gr. N10276 (solution annealed condition) or SB575 Gr. N10276 (solution annealed condition)	
Hub material	SB574 Gr. N10276 (solution annealed condition)	

Table 17: Alloy 400 (UNS N04400) Flanges

Item	ASME	EN, JIS
Bolting material	UNS N04400	UNS N04400
Gasket	Soft (1a) with min. thickness 1.6 mm or Spiral wound gasket with nonmetallic filler (1b)	Soft (EN 1514-1) with min. thickness 1.6 mm or Spiral wound gasket with nonmetallic filler (EN 1514-2)
Flange material	SB/B564 Gr. N04400 (solution annealed condition) or SB/B127 Gr. N04400 (solution annealed condition)	
Hub material	SB164 Gr. N04400 (solution annealed condition)	

Air purging

An air purge connection can prevent clogging of the antenna in extreme applications with dirt or heavy coating. To determine if air purging is needed, inspect the tank internal conditions at the location intended for the transmitter. If there is normally a thick layer of product build-up there, air purging is most likely needed. Typical purging media to use is air.

All parabolic antennas come with an integrated air purge connection (see [Figure 13](#)).

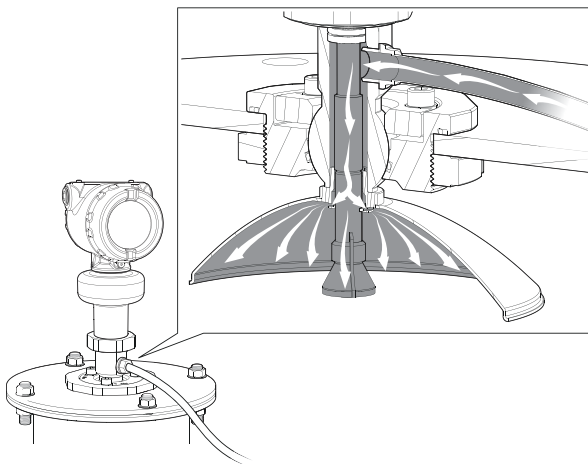
Figure 13: Air Purging for Parabolic Antenna

An air purge connection is available for cone antennas with flanged connection by selecting option code PC1. This option consists of an antenna with purge holes and a separate air purge ring (see [Figure 14](#)).

Figure 14: Air Purging for Cone Antenna

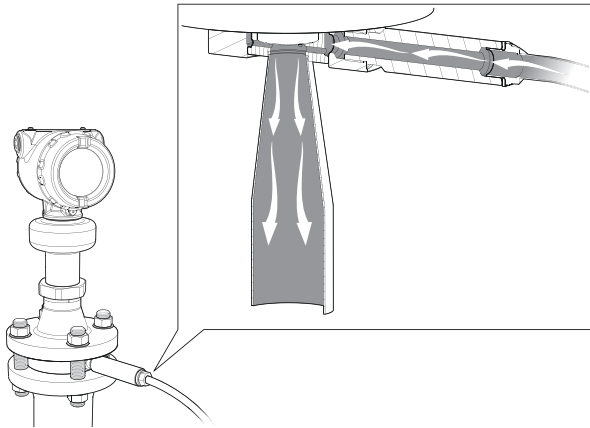

Flushing connection rings are available as accessory for use with process seal antennas.

Figure 15: Air Purging for Process Seal Antenna

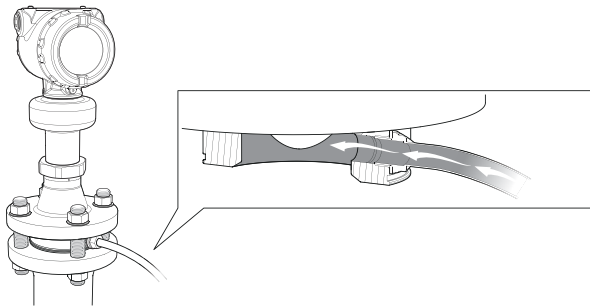

Incoming air supply specification

- Maximum pressure: 190 psi (13 bar)
- Recommended pressure: 100 to 115 psi (7 to 8 bar)
- Inlet/outlet connection: BSPP (G) 3/8-in.
- Air consumption: 252 gal/min at 65 psi (955 l/min at 4.5 bar)

System integration

Rosemount 333 HART® Tri-Loop™

By sending the digital HART signal to the optional HART Tri-Loop, it is possible to have up to three additional 4–20 mA analog signals.



Related information

[Rosemount 333 Product Data Sheet](#)

Emerson Wireless 775 THUM™ Adapter

The optional Emerson Wireless 775 THUM Adapter can be mounted directly on the transmitter or by using a remote mounting kit.



IEC 62591 (*WirelessHART*®) enables access to multivariable data and diagnostics, and adds wireless to almost any measurement point.

Related information

[Emerson Wireless 775 THUM Adapter Product Data Sheet](#)

Physical specifications

Material selection

Emerson provides a variety of Rosemount products with various product options and configurations, including materials of construction that can be expected to perform well in a wide range of applications.

The product information presented is intended as a guide for the purchaser to make an appropriate selection for the application. It is the purchaser's sole responsibility to make a careful analysis of all process parameters (such as all chemical components, temperature, pressure, flow rate, abrasives, contaminants, etc.), when specifying product, materials, options, and components for the particular application. Emerson is not in a position to evaluate or guarantee the compatibility of the process fluid or other process parameters with the product, options, configuration, or materials of construction selected.

Transmissible Spongiform Encephalopathy (TSE) declaration

This declaration is applicable to Tri Clamp connections.

Emerson certifies no process wetted components used in this product contain substances of animal origin. Materials used in the production or processing of wetted components for this product meet the requirements stated in EMA/410/01 Rev. 3 and ISO 22442-1:2015. Wetted components in this product are considered free of TSE.

Engineered solutions

When standard model codes are not sufficient to fulfill requirements, please consult the factory to explore possible Engineered Solutions. This is typically, but not exclusively, related to the choice of wetted materials or the design of a process connection. These Engineered Solutions are part of the expanded offerings and may be subject to additional delivery lead time. For ordering, factory will supply a special P-labeled numeric option code that should be added at the end of the standard model string.

Housing and enclosure

Electrical connections

Two cable/conduit entries ($\frac{1}{2}$ -14 NPT, M20 x 1.5, or G $\frac{1}{2}$)

Optional adapters: M12 4-pin male eurofast connector or A size Mini 4-pin male minifast connector

Materials

- Electronics housing: Polyurethane-covered Aluminum or Stainless Steel Grade CF-8M (ASTM A743)
- Sensor module: 316L SST

Weight

- Aluminum housing: 6.2 lb (2.8 kg)⁽⁷⁾
- Stainless steel housing: 10.0 lb (4.5 kg)⁽⁷⁾

Ingress protection

IP 66/67/68⁽⁸⁾ and NEMA[®] 4X

Tank connection

The tank connection consists of a tank seal, a flange, NPT or BSPP (G) threads, Tri Clamp, or a specific welded connection with swivel feature for parabolic antenna.

Flange dimensions

Follows ASME B16.5, JIS B2220, and EN 1092-1 standards.

Related information

[Standard flanges](#)

Tri Clamp connection

Follows ISO 2852 standard.

Antenna versions

Cone antenna

- Best choice for most applications, including closed vessels, still pipe/chamber installations, and open air applications
- Extended cone antennas are available for tall nozzles (option code S1 and S2). Depending on measurement conditions, a reduction of sensitivity close to antenna end might be present.

(7) Fully functional transmitter with sensor module, housing, terminal block, LCD display, and covers.

(8) The transmitter meets IP 68 at 9.8 ft. (3 m) for 30 minutes.

Process seal antenna

- All PTFE wetted parts ideal for use in corrosive and hygienic applications
- Suitable for applications with heavy condensation/build-up

Parabolic antenna

- Alternative for long measuring ranges in combination with conditions such as low reflective media
- Suitable for a broad range of solid materials (may need air purging in dusty environments)

Material exposed to tank atmosphere

Cone antenna, PTFE seal

- 316/316L SST (EN 1.4404), Alloy C-276 (UNS N10276), or Alloy 400 (UNS N04400)
- PTFE fluoropolymer

Cone antenna, PEEK seal

- 316/316L SST (EN 1.4404), Alloy C-276 (UNS N10276), or Alloy 400 (UNS N04400)
- PEEK polyetheretherketone
- FVMQ fluorosilicone, Kalrez® 6375 perfluoroelastomer, FKM fluoroelastomer, or Viton® fluoroelastomer (O-ring)

Process seal antenna

- PTFE fluoropolymer

Parabolic antenna

- 316/316L SST (EN 1.4404)
- PTFE fluoropolymer
- FVMQ fluorosilicone (O-ring)

Installation considerations

Before installing the device, follow recommendations for mounting position, sufficient free space, nozzle requirements, etc.

Mounting position

When finding an appropriate location on the tank for the device, the conditions of the tank must be carefully considered.

Consider the following guidelines when mounting the device:

- For optimal performance, the device should be installed in locations with a clear and unobstructed view of the product surface.
- The device should be mounted with as few internal structures as possible within the radar beam.
- Do not install the device in the center of the tank.
- Do not mount close to or above the inlet stream.
- Multiple Rosemount 5408 devices can be used in the same tank without interfering with each other.

Figure 16: Recommended Mounting Position

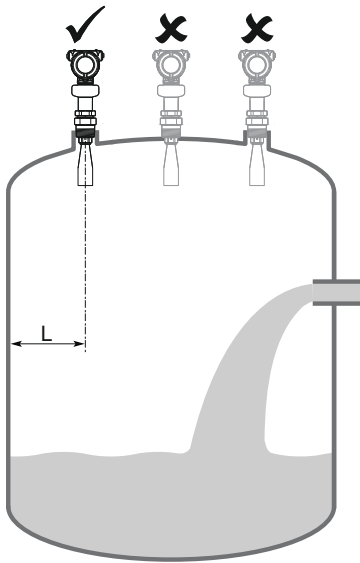

Free space requirements

If the device is mounted close to a wall or other tank obstruction such as heating coils and ladders, noise might appear in the measurement signal. See [Table 18](#) for recommended clearance.

For easy access to the device, mount it with sufficient service space (see [Table 19](#)).

Figure 17: Free Space Requirements

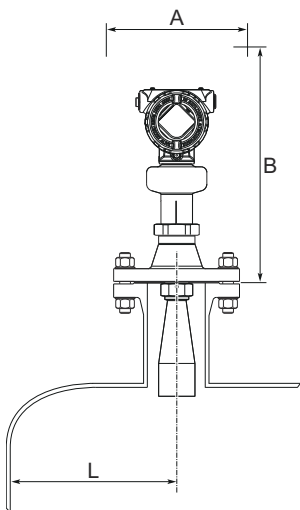

Table 18: Distance to Tank Wall (L)

Application	Minimum	Recommended
Liquids	8 in. (200 mm)	½ of tank radius
Solids	8 in. (200 mm)	⅔ of tank radius

Table 19: Free Space Requirements

Description	Distance
Service space width (A)	20 in. (500 mm)
Service space height (B)	24 in. (600 mm)

Antenna size

Choose as large antenna diameter as possible. A larger antenna diameter concentrates the radar beam and ensures maximum antenna gain. Increased antenna gain permits greater margin for weak surface echoes.

In addition, a larger antenna diameter results in a smaller beam angle and thereby, less interference from any internal structures in the tank.

Antenna inclination

Ensure the antenna is aligned perpendicular to the product surface (see [Figure 18](#)). The parabolic antenna comes with a swivel connection that adjusts for angled tank roofs.

Note that if the surface echo is weak in solids applications, then a small inclination of the parabolic antenna toward the surface slope may improve the performance.

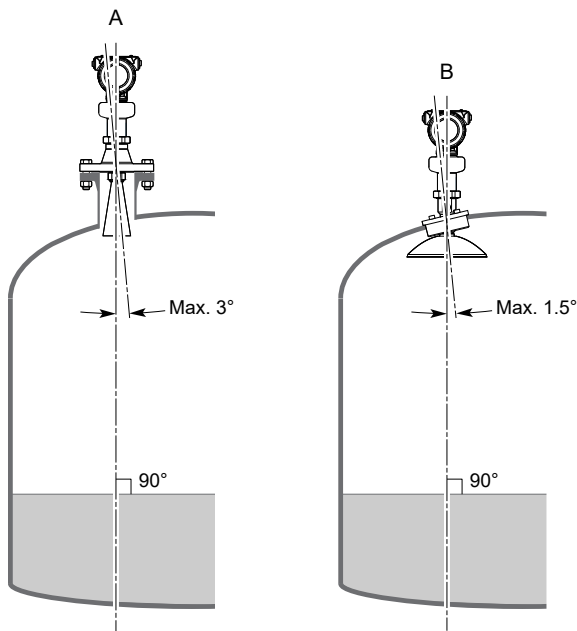
Figure 18: Inclination

- A. Cone antenna/process seal antenna
- B. Parabolic antenna

Non-metallic tanks

Nearby objects outside the tank may cause disturbing radar echoes. Wherever possible, the device should be positioned so that objects close to the tank are kept outside the radar beam.

Beam width and beam angle

The device should be mounted with as few internal structures as possible within the radar beam. Refer to [Table 20](#) for beam angle and [Table 21](#) for beam width at different distances.

Figure 19: Beam Angle and Beam Width

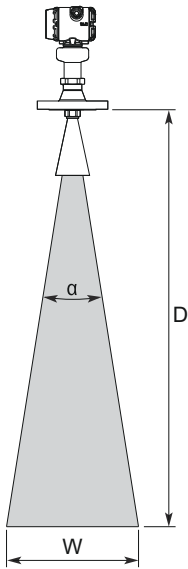

Table 20: Beam Angle

Antenna size	Beam angle (α)
1½-in. (DN 40) cone	22°
2-in. (DN50) cone/process seal	18°
3-in. (DN80) cone/process seal	14°
4-in. (DN100) cone/process seal	10°
8-in. (DN200) parabolic	4.5°

Table 21: Beam Width, ft. (m)

Distance (D)	Beam width (W)				
	1½-in. cone	2-in. cone/process seal	3-in. cone/process seal	4-in. cone/process seal	Parabolic
16 (5)	6.2 (1.9)	5.2 (1.6)	4.0 (1.2)	2.9 (0.9)	1.3 (0.4)
33 (10)	12.8 (3.9)	10.4 (3.2)	8.1 (2.5)	5.7 (1.8)	2.6 (0.8)
49 (15)	19.0 (5.8)	15.6 (4.8)	12.1 (3.7)	8.6 (2.6)	3.9 (1.2)
66 (20)	25.6 (7.8)	20.8 (6.3)	16.1 (4.9)	11.5 (3.5)	5.2 (1.6)
82 (25)	31.8 (9.7)	26.0 (7.9)	20.1 (6.1)	14.3 (4.4)	6.4 (2.0)
98 (30)	38.4 (11.7)	31.2 (9.5)	24.2 (7.4)	17.2 (5.3)	7.7 (2.4)
131 (40)	51.2 (15.6)	41.6 (12.7)	32.2 (9.8)	23.0 (7.0)	10.3 (3.1)
197 (60)	N/A	N/A	N/A	34.5 (10.5)	15.4 (4.7)
262 (80)	N/A	N/A	N/A	45.9 (14.0)	20.7 (6.3)
328 (100)	N/A	N/A	N/A	57.4 (17.5)	25.9 (7.9)
492 (150)	N/A	N/A	N/A	86.0 (26.2)	38.7 (11.8)

Nozzle requirements

To allow the microwaves to propagate undisturbed, the nozzle dimensions should be kept within the specified limits as given in [Table 22](#), [Table 23](#), and [Table 24](#).

Nozzle requirements for cone antenna

For best performance, the cone antenna should extend at least 0.4 in. (10 mm) below the nozzle. If required, use the extended cone antenna versions (option code S1 or S2).

However, the antenna can be recessed in smooth nozzles up to 4 ft. (1.2 m). Note that if the inside of the nozzle has irregularities (e.g. due to bad welding, rust, or deposit), then use the extend cone antenna.

Figure 20: Mounting of the Cone Antenna

Table 22: Nozzle Requirements for Cone Antenna, in Inches (Millimeters)

Antenna size	Minimum nozzle diameter (D) ⁽¹⁾	Recommended maximum nozzle height (H) ⁽²⁾⁽³⁾	
		Antenna	Antenna with air purge ring (code PC1)
1½-in. (DN 40)	1.50 (38.1)	5.59 (142)	N/A
2-in. (DN50)	1.94 (49.3)	5.71 (145)	4.69 (119)
3-in. (DN80)	2.80 (71.0)	5.63 (143)	4.61 (117)
4-in. (DN100)	3.78 (96.0)	6.54 (166)	5.51 (140)

- (1) The antennas are sized to fit within schedule 80 or lower schedules.
- (2) The values are valid for cone antennas without antenna extension.
- (3) For liquid applications, the cone antenna can be recessed in smooth nozzles up to 4 ft. (1.2 m), but note that the accuracy may be reduced in the region close to the nozzle.

Nozzle requirements for process seal antenna

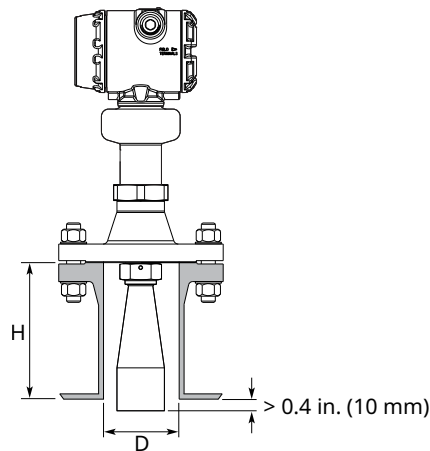
The antenna can be used on nozzles up to 4 ft. (1.2 m). Disturbing objects inside the nozzle may impact the measurement, and should therefore be avoided.

Figure 21: Mounting of the Process Seal Antenna

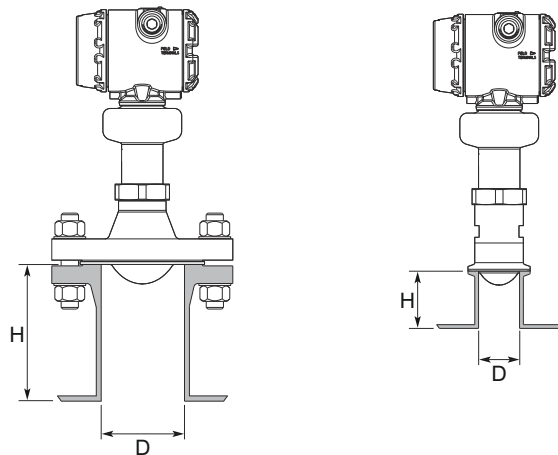

Table 23: Nozzle Requirements for Process Seal Antenna

Antenna size	Minimum nozzle diameter (D) ⁽¹⁾	Recommended maximum nozzle height (H) ⁽²⁾
2-in. (DN50)	1.77 in. (45 mm)	4 ft. (1.2 m)
3-in. (DN80)	2.76 in. (70 mm)	4 ft. (1.2 m)
4-in. (DN100)	2.76 in. (70 mm)	4 ft. (1.2 m)

- (1) The antennas are sized to fit within schedule 120 or lower schedules.
- (2) For hygienic applications, the nozzle height (H) must not exceed two times the nozzle diameter (D) to ensure cleanability. Maximum nozzle height is 5 in. (127 mm).

Nozzle requirements for parabolic antenna

See [Table 24](#) for nozzle height recommendations at different inclination angle.

Figure 22: Mounting of the Parabolic Antenna

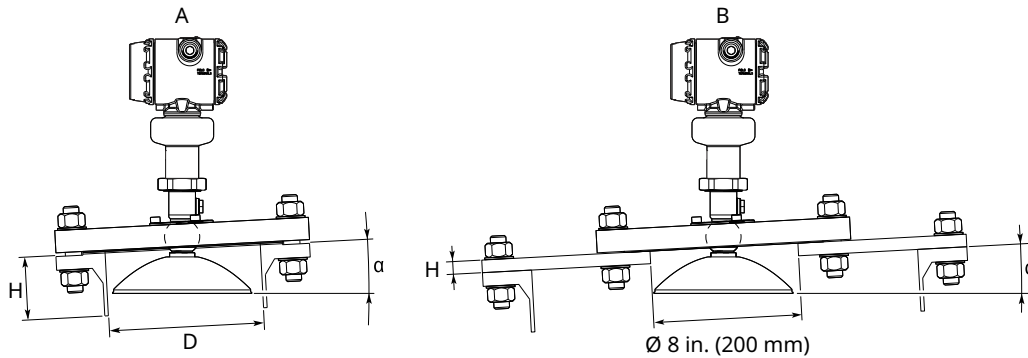

- A. Nozzle mounting
- B. Flange mounting in manhole cover

Table 24: Nozzle Requirements for Parabolic Antenna, in Inches (Millimeters)

Nozzle size (D)	Inclination angle (α)	Maximum nozzle height (H) ⁽¹⁾
Pipe schedule std, Ø 8 in. (200 mm)	0°	6.1 (155)
	3°	3.4 (85)
	6°	1.6 (40)
	9°	1.2 (30)
	12°	1.0 (25)
	15°	0.6 (15)
Pipe schedule std, Ø10 in. (250 mm)	0°	17.2 (440)
	3°	10.2 (260)
	6°	7.1 (180)
	9°	5.1 (130)
	12°	3.9 (100)
	15°	3.0 (75)

(1) Note that the inside of the nozzle must be smooth (i.e. avoid bad welding, rust, or deposit).

Still pipe/chamber installations

Installation in still pipe/chamber is recommended for tanks where there are excessive foaming or turbulence. Still pipe/chamber may also be used to avoid disturbing objects in the tank.

Still pipe

Consider the following still pipe requirements:

- Pipe**
 - Pipes should be an all-metal material.
 - Pipe should have a constant inside diameter.
 - The inner surface must be smooth and clear of any rough edges. (Smooth pipe joints are acceptable, but may reduce accuracy.)
 - The end of the pipe must extend beyond the zero level.

- Holes**
- Maximum hole diameter is 1 in. (25 mm).
 - Minimum distance between holes is 6 in. (150 mm).
 - Holes should be drilled on one side only and deburred.
 - Drill one hole above maximum product surface.
- Antenna**
- All cone/process seal antenna sizes can be used for still pipe/chamber installations.
 - The gap between the cone antenna and the still pipe should be maximum 0.2 in. (5 mm)⁽⁹⁾. Larger gaps may result in inaccuracies. If required, order a larger antenna and cut on location.

Figure 23: Still Pipe Requirements

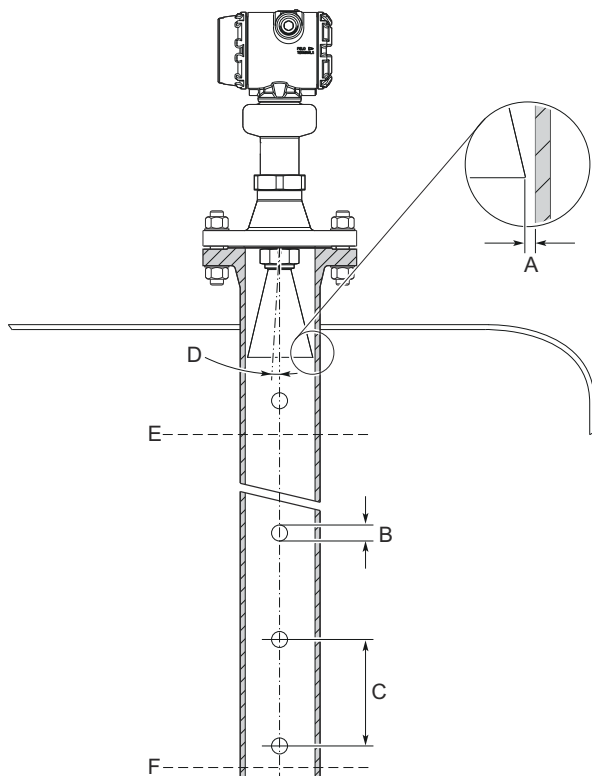

- A. Maximum 0.2 in. (5 mm)
 B. Maximum 1 in. (25 mm)
 C. Minimum 6 in. (150 mm)
 D. Maximum 1°
 E. Level = 100%
 F. Level = 0%

Chamber

Consider the following chamber requirements:

- Pipes should be an all-metal material.
- Pipe should have a constant inside diameter.
- Inlet pipes should not protrude into the inside of the stand pipe.

(9) A larger gap is inevitable for the 4-in. cone antenna in pipes with a diameter larger than 4 in.

- The inner surface must be smooth and clear of any rough edges. (Smooth pipe joints are acceptable, but may reduce accuracy.)
- The gap between the cone antenna and the stand pipe should be maximum 0.2 in. (5 mm)⁽⁹⁾. Larger gaps may result in inaccuracies. If required, order a larger antenna and cut on location.

Figure 24: Chamber Requirements

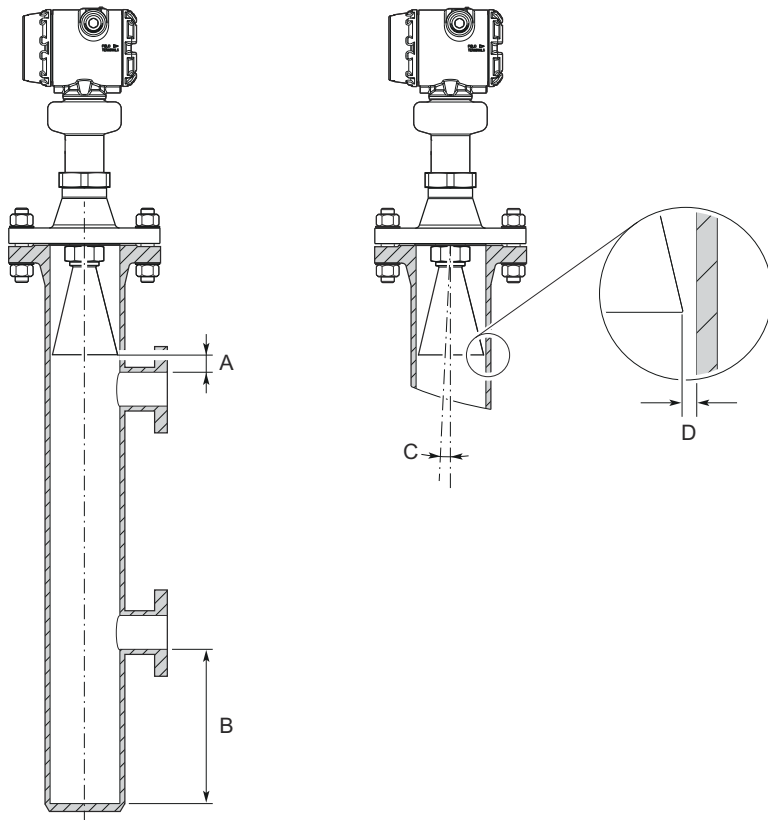

- A. Minimum 0.4 in. (10 mm)
- B. Minimum 6 in. (150 mm)
- C. Maximum 1°
- D. Maximum 0.2 in. (5 mm)

Related information

[Best Practices for Using Radar in Still Pipes and Chambers Technical Note](#)

Ball valve installation

The device can be isolated from the process by using a valve:

- Use a full-port ball valve.
- Ensure there is no edge between the ball valve and the nozzle or still pipe, the inside should be smooth.
- Valves can be combined with still pipes.
- The ball valve should have the same inner diameter as the still pipe.

Shipboard installations

Devices with aluminum housing are not approved for open deck installations; for use only in engine room, pump room, etc.

For application conditions and limitations refer to the applicable shipboard approval.

Product certifications

See the Rosemount 5408 [Product Certifications](#) document for detailed information on the existing approvals and certifications.

Dimensional drawings

Figure 25: Cone Antenna with Flanged Process Connection

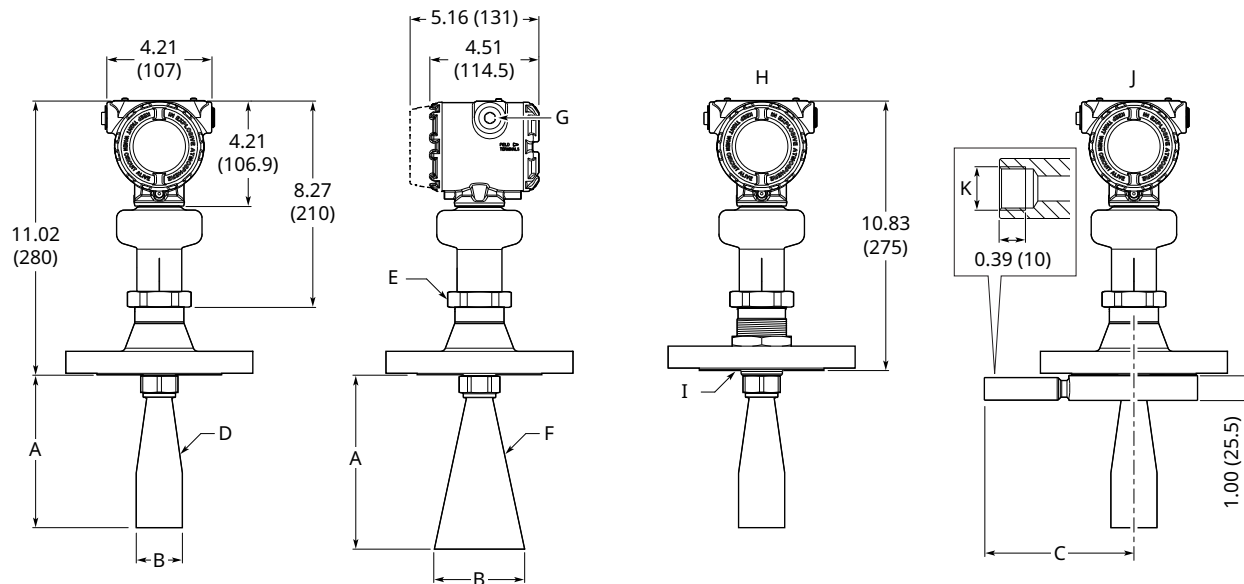

- A. See [Table 25](#) for dimensions.
- B. See [Table 25](#) for dimensions.
- C. See [Table 25](#) for dimensions.
- D. 2-in. (DN50) cone style
- E. s60
- F. 3-in. (DN80) and 4-in. (DN100) cone style
- G. ½-14 NPT, M20 x 1.5, or G½; optional adapters: eurofast® and minifast®
- H. Protective plate design
- I. Protective plate
- J. Purging connector (option code PC1)
- K. G¾-in.

Dimensions are in inches (millimeters).

Table 25: Cone Antenna Dimensions

Cone size	A	B	C
1½-in. (DN40)	5.98 in. (152 mm)	1.38 in. (35 mm)	N/A
2-in. (DN50)	6.10 in. (155 mm)	1.85 in. (47 mm)	5.39 in. (137 mm)
3-in. (DN80)	6.02 in. (153 mm)	2.64 in. (67 mm)	6.77 in. (172 mm)
4-in. (DN100)	6.93 in. (176 mm)	3.62 in. (92 mm)	7.80 in. (198 mm)

Figure 26: Cone Antenna with Threaded Process Connection

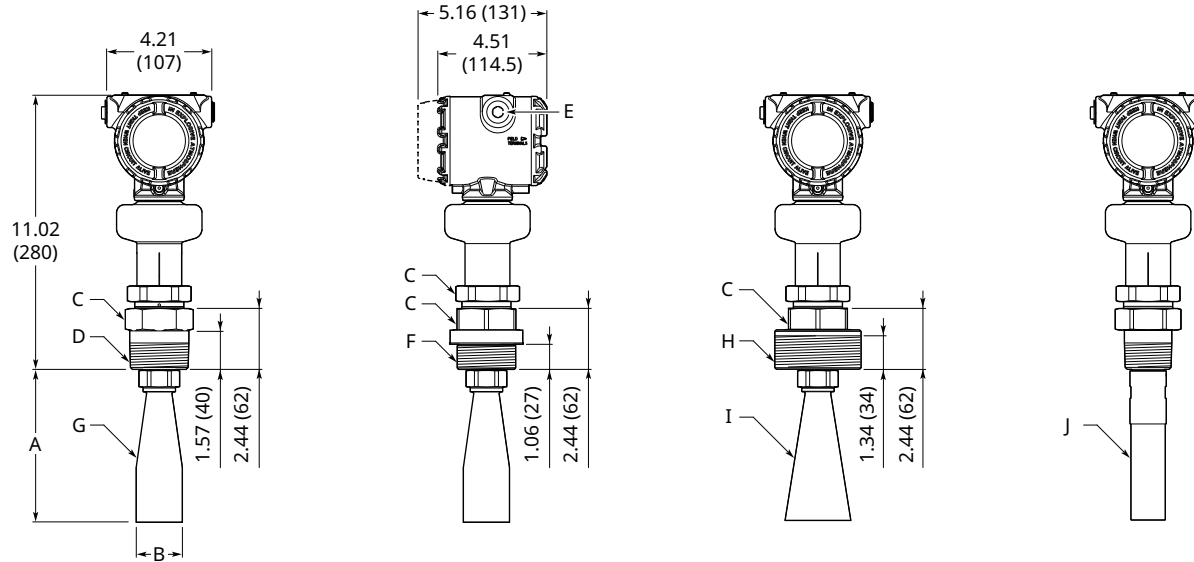

- A. See [Table 25](#) for dimensions.
- B. See [Table 25](#) for dimensions.
- C. s60
- D. NPT 1½-, 2-, 3-, 4-in.
- E. ½-14 NPT, M20 x 1.5, or G½; optional adapters: eurofast and minifast
- F. BSPP (G) 1½-, 2-in.
- G. 2-in. (DN50) cone style
- H. BSPP (G) 3-, 4-in.
- I. 3-in. (DN80) and 4-in. (DN100) cone style
- J. 1½-in. (DN40) cone style

Dimensions are in inches (millimeters).

Figure 27: Extended Cone Antenna

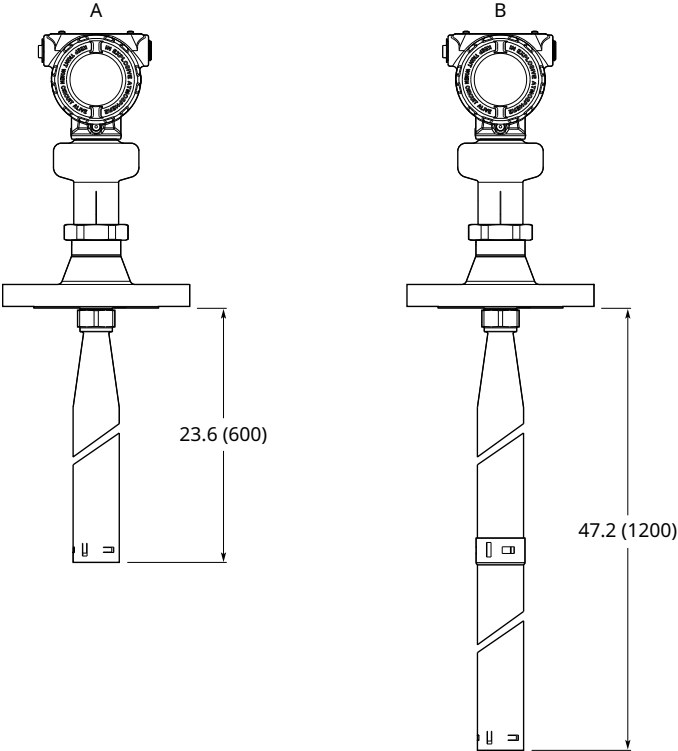

- A. Option code S1
- B. Option code S2

Dimensions are in inches (millimeters).

Figure 28: Cone Antenna with Bracket Mounting

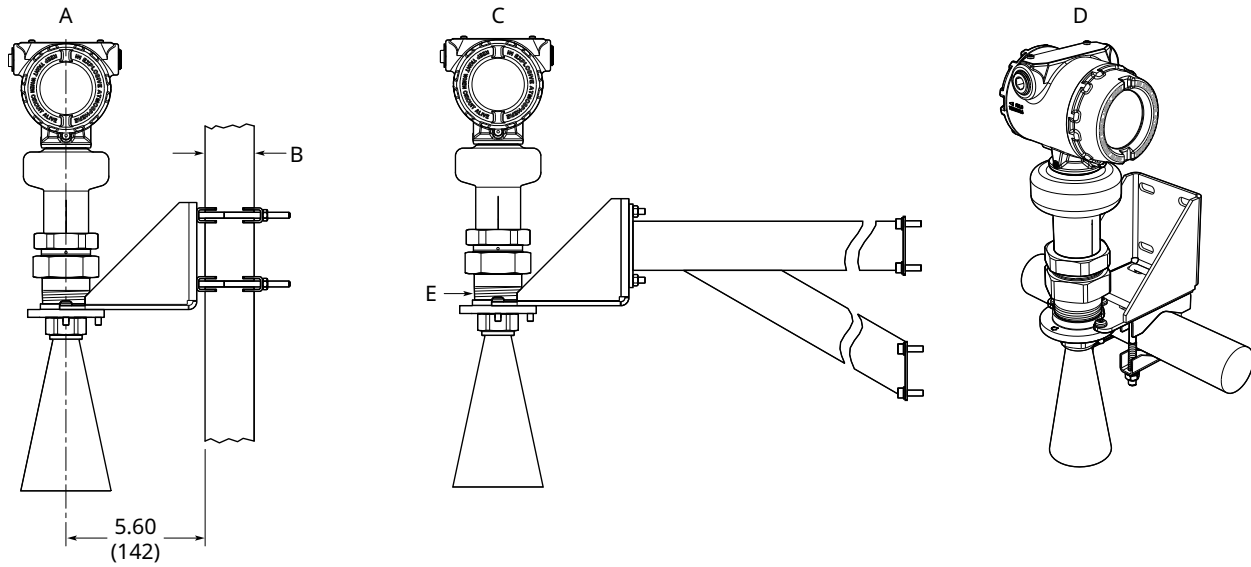

- A. Pipe mounting (vertical pipe)
- B. Pipe diameter, max 2.52 in. (64 mm)
- C. Wall mounting (see [Figure 33](#) for hole pattern)
- D. Pipe mounting (horizontal pipe)
- E. NPT 1½-in.

Dimensions are in inches (millimeters).

Figure 29: Process Seal Antenna

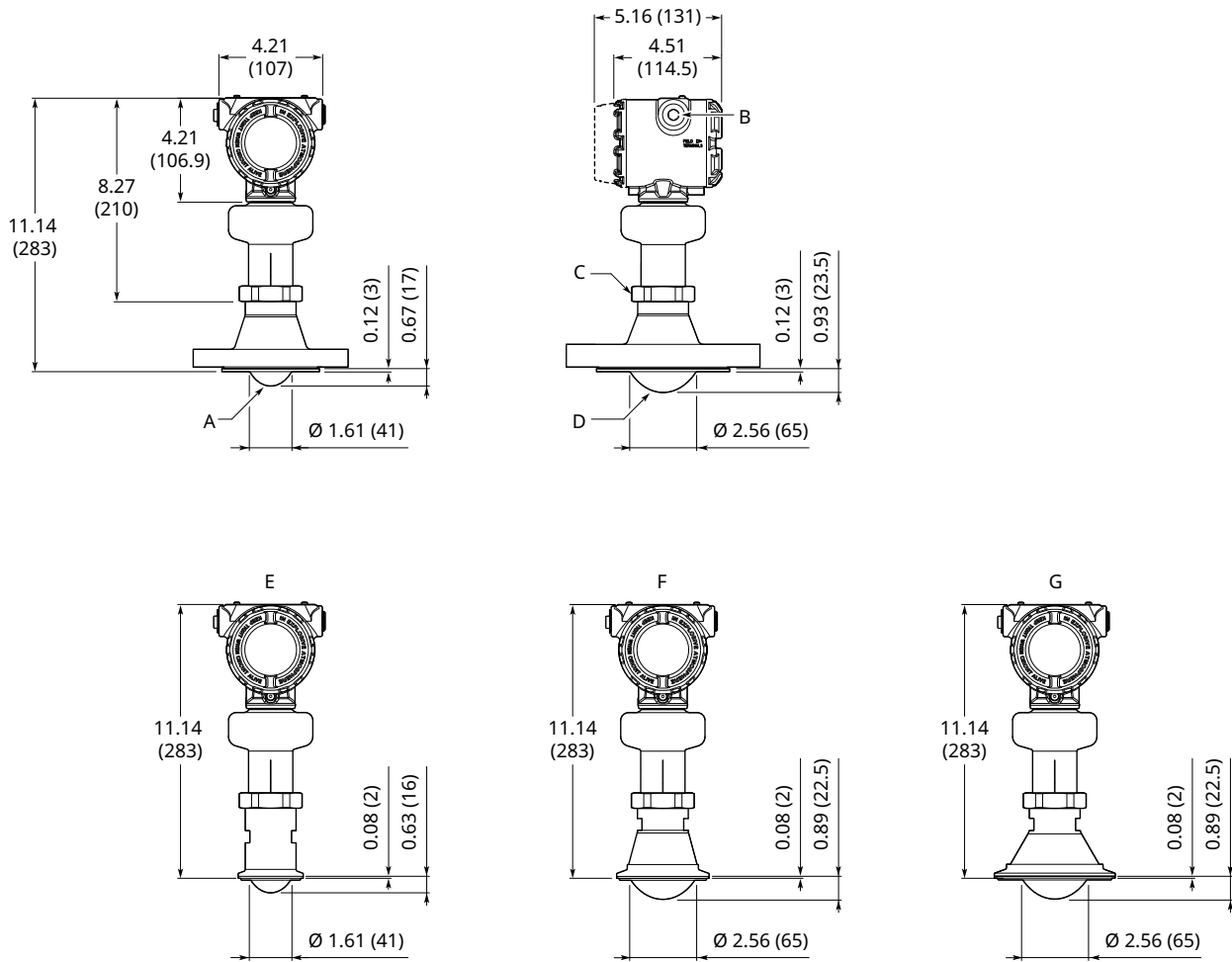

- A. 2-in. (DN50) process seal style
- B. ½-14 NPT, M20 x 1.5, or G½; optional adapters: eurofast and minifast
- C. s60
- D. 3-in. (DN80) and 4-in. (DN100) process seal style
- E. 2-in. Tri Clamp
- F. 3-in. Tri Clamp
- G. 4-in. Tri Clamp

Dimensions are in inches (millimeters).

Figure 30: Process Seal Antenna with Bracket Mounting

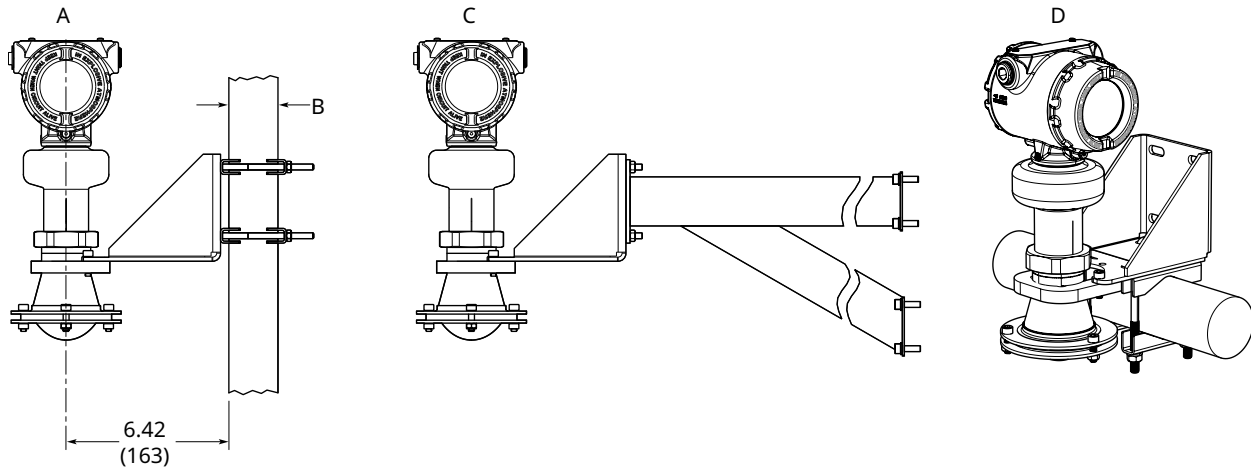

- A. Pipe mounting (vertical pipe)
- B. Pipe diameter, max 2.52 in. (64 mm)
- C. Wall mounting (see [Figure 33](#) for hole pattern)
- D. Pipe mounting (horizontal pipe)

Dimensions are in inches (millimeters).

Figure 32: Parabolic Antenna with Bracket Mounting

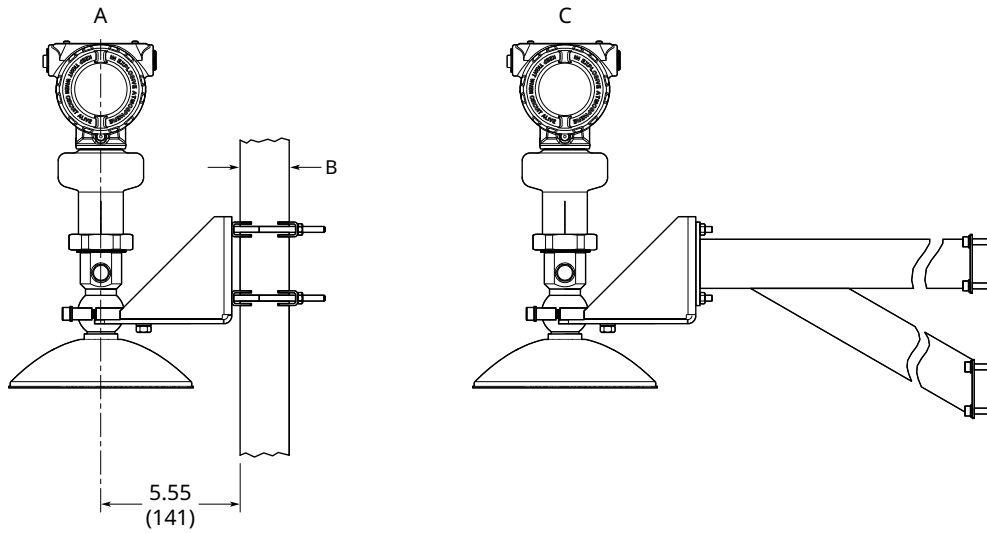

- A. Pipe mounting (vertical pipe)
- B. Pipe diameter, max 2.52 in. (64 mm)
- C. Wall mounting (see [Figure 33](#) for hole pattern)

Dimensions are in inches (millimeters).

Figure 33: Hole Pattern for Wall Mounting

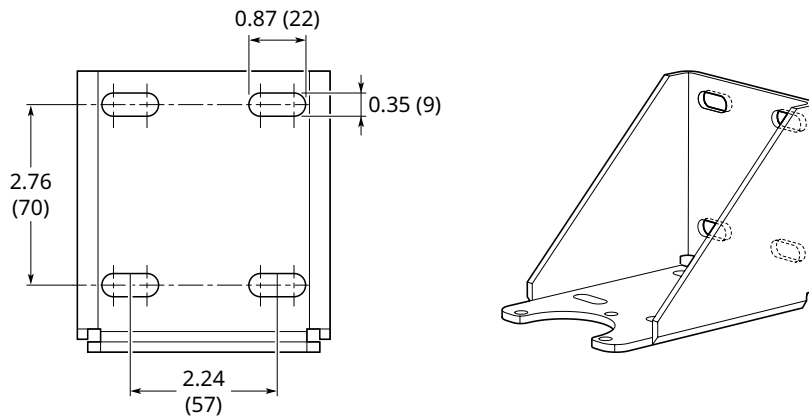

Dimensions are in inches (millimeters).

Standard flanges

Figure 34: Cone Antenna Flange Connection

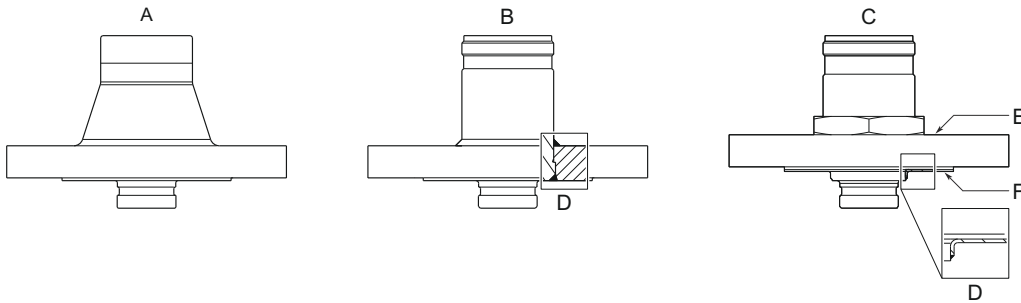

- A. Forged one-piece
- B. Welded construction
- C. Protective plate design
- D. Weld
- E. Backing flange
- F. Protective plate

Table 26: Standard Flanges for Cone Antenna

Standard	Face type ⁽¹⁾	Face surface finish, R _a
ASME B16.5	Raised face	125-250 μin
	Ring type joint	< 63 μin
EN 1092-1	Type B1 raised face	3.2-12.5 μm
	Type A flat face	3.2-12.5 μm
JIS B2220	Raised face	3.2-6.3 μm

(1) Face gasket surface is serrated per mating standard.

Table 27: Cone Antennas with Protective Plate

Standard	Face type including protective plate	Plate surface finish, R _a
ASME B16.5	Raised face	3.2-6.3 μm
EN 1092-1	Raised face	3.2-6.3 μm
JIS B2220	Raised face	3.2-6.3 μm

Figure 35: Parabolic Antenna Flange Connection



Table 28: Standard Flanges for Parabolic Antenna

Standard	Face type ⁽¹⁾	Face surface finish
ASME B16.5	Raised face	125-250 μin
EN 1092-1	Type A flat face	3.2-12.5 μm
JIS B2220	Raised face	3.2-12.5 μm

(1) Face gasket surface is serrated per mating standard.

Flushing connection rings

Figure 36: Flushing Connection Rings

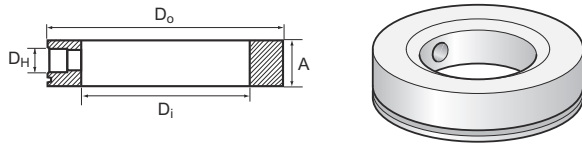

A. Height: 0.97 in. (24.6 mm)

Table 29: Dimensions of Flushing Connection Rings

Flushing connection rings	D _i	D _o	D _H
2-in. ANSI	2.12 (53.8)	3.62 (91.9)	¼-in. NPT
3-in. ANSI	3.60 (91.4)	5.00 (127.0)	¼-in. NPT
4-in. ANSI/DN100	3.60 (91.4)	6.20 (157.5)	¼-in. NPT
DN50	2.40 (61.0)	4.00 (102.0)	¼-in. NPT
DN80	3.60 (91.4)	5.43 (138.0)	¼-in. NPT

For more information: [Emerson.com/global](https://emerson.com/global)

©2025 Emerson. All rights reserved.

Emerson Terms and Conditions of Sale are available upon request. The Emerson logo is a trademark and service mark of Emerson Electric Co. Rosemount is a mark of one of the Emerson family of companies. All other marks are the property of their respective owners.

ROSEMOUNT™

