

Rosemount™ 2090F Hygienic Pressure Transmitter



Marketing blurb

- Conforms to 3-A™ Sanitary Standards
- Features CIP/SIP service for process temperatures up to 284 °F (140 °C)
- Absolute or gage pressure ranges up to 300 psi
- Utilizes Rosemount solid-state, polysilicon sensor for industry leading reliability and performance

Accurate, stable, and reliable pressure measurement for the hygienic industries

Conforms to 3-A Sanitary Standards

The hygienic design of the Rosemount 2090F conforms to 3-A Sanitary Standards, and is USDA accepted. The materials of construction are Generally Recognized As Safe (GRAS) by the FDA, making it the ideal choice for any hygienic application.

Features CIP/SIP service with an upper temperature limit of 284 °F (140 °C)

The Rosemount 2090F provides accurate, stable, and reliable pressure measurement, which makes it an ideal choice for pharmaceutical and food and beverage applications, including CIP/SIP service for process temperatures up to 284 °F (140 °C).

Absolute or gauge pressure ranges up to 300 psi and 20:1 turndown

Higher turndown allows for lower inventories by allowing you to measure pressures from 1.5 to 300 psi with only three transmitter ranges.

Mounts with either 1 1/2 or 2-in. Tri Clamp connection

The Rosemount 2090F is available with both 1 1/2 and 2-in. Tri Clamp process connections, designed for sanitary applications to easily connect to standard sanitary fittings without requiring special mounting hardware.

0.10 percent reference accuracy performance with P8 high accuracy option

The single-filled sensor system of the Rosemount 2090F leads to outstanding accuracy due to full sensor compensation.

Contents

Accurate, stable, and reliable pressure measurement for the hygienic industries.....	2
Ordering information.....	3
Specifications.....	6
Product Certifications.....	9
Dimensional drawings.....	10

Ordering information

Specification and selection of product materials, options, or components must be made by the purchaser of the equipment. See [Material selection](#) for more information on Material Selection.

Table 1: Rosemount 2090F Pressure Transmitter Ordering Information

The starred offerings (★) represent the most common options and should be selected for best delivery. The non-starred offerings are subject to additional delivery lead time.

Model	Product Description			
2090F	Hygienic Pressure Transmitter			
Transmitter Type				
A	Absolute			★
G	Gage			★
Pressure ranges (range/minimum span)				
	Rosemount 2090FG	Rosemount 2090FA		
1	-14.7 to 30 psi/1.5 psi (-1.01 to 2.1 bar/103 mbar)	0 to 30 psia/1.5 psi (0 to 2.1 bar/103 mbar)		★
2	-14.7 to 150 psi/7.5 psi (-1.01 to 10.3 bar/517 mbar)	0 to 150 psia/7.5 psi (0 to 10.3 bar/517 mbar)		★
3	-14.7 to 300 psi/40 psi (-1.01 to 20.7 bar/2.8 bar)	0 to 300 psia/40 psi (0 to 20.7 bar/2.8 bar)		★
Output				
S	4 to 20 mA dc/digital HART® Protocol			★
Material of Construction				
	Process connection	Isolating diaphragm	Oil fill	
2D	316L SST (Stainless Steel)	316L SST	Neobee®	★
Process Connection				
E	1 1/2-in. Tri Clamp connection			★
F	2-in. Tri Clamp connection			★
Conduit Entry				
1	1/2-14 NPT			★
2	M20 3 1.5 female			★
Options (include with selected model number)				
Extended Product Warranty				
WR3	3-year limited warranty			★
WR5	5-year limited warranty			★
Digital Display				
M5	LCD display, configured for percent of range			★
Mounting Brackets				
B4	SST mounting bracket with SST bolts			★
Product Certifications				
E5	USA Explosionproof (XP) and Dust-Ignitionproof (DIP)			★
ED	ATEX Flameproof			★
EM	Technical Regulations Customs Union (EAC) Flameproof			★

Table 1: Rosemount 2090F Pressure Transmitter Ordering Information (continued)

I5	USA Intrinsic Safety (IS) and Nonincendive (NI)	★
K5	USA Explosionproof (XP), Dust-Ignitionproof (DIP), Intrinsic Safety (IS), and Nonincendive (NI)	★
I1	ATEX Intrinsic Safety	★
N1	ATEX Type n	★
C6	Canada Explosionproof, Intrinsic Safety, Division 2, and Dust-Ignitionproof	★
KB	USA Explosionproof, Dust-Ignitionproof, Intrinsic Safety, Nonincendive and Canada Explosionproof, Intrinsic Safety, Division 2, and Dust-Ignitionproof	★
KM	Technical Regulation Customs Union (EAC) Flameproof and Intrinsic Safety	★
KH	ATEX Flameproof, Intrinsic Safety, USA Explosionproof, Dust-Ignitionproof, Intrinsic Safety, and Nonincendive	★
ND	ATEX Dust	★
NK	IECEX Dust	★
K7	IECEX Flameproof, Dust, Intrinsic Safety, Type n	★
K1	ATEX Flameproof, Dust, Intrinsic Safety, Type n	★
K6	Canada Explosion-Proof, Intrinsic Safety, Division 2, Dust-ignitionproof, and ATEX Flameproof, Intrinsic Safety	★
I3	China Intrinsic Safety	★
IM	Technical Regulation Customs Union (EAC) Intrinsic Safety	★
E3	China Flameproof	★
IP	Republic of Korea Intrinsic Safety	★
KP	Republic of Korea Flameproof, Intrinsic Safety	★
Terminal Blocks		
T1	Transient protection	★
Special Certificate		
Q4	Calibration certificate	★
Quality calibration certificate traceability certification		
Q8	Material traceability certification per EN 10204 3.1	★
Alarm Limit		
C4	NAMUR alarm and saturation levels, high alarm	★
CN	NAMUR alarm and saturation levels, low alarm	★
Special Procedures		
P2	Cleaning for special service	
Calibration Accuracy		
P8	0.1 percent accuracy to 10:1 turndown	★
Typical Model Number: 2090F G 2 S 2D E 1		

Standard configuration

Unless otherwise specified, transmitter is shipped as follows:

- Engineering units: psi
- 4 mA: 0 psi
- 20 mA: Upper range limit
- Alarm output: high
- LCD display: 0 to 100 percent

Custom configuration

Calibration

Transmitters are factory calibrated to customer's specified range. If calibration is not specified, transmitters are calibrated at maximum range. Calibration is at ambient temperature and pressure.

Tagging

The transmitter will be tagged, at no charge, in accordance with customer requirements. All tags are stainless steel. The standard tag is wired to the transmitter. Tag character height is 1/8-in. (0.318 cm). A permanently attached tag is available upon request.

Accessories

Item description	Part number
Calibration adapter, 1 1/2-in. Use to connect a calibration device to a transmitter.	02088-0197-0011
Calibration adapter, 2-in. Use to connect a calibration device to a transmitter.	02088-0197-0012

Specifications

Functional specifications

Service

Liquid, gas, vapor, and high-viscosity applications

Ranges

Range	Minimum span	Upper (URL)	Lower (LRL)	Lower ⁽¹⁾ (LRL) (gage)
1	1.5 psi (103 mbar)	30 psi (2.1 bar)	0 psia (0 bar)	-14.7 psig (-1.01 bar)
2	7.5 psi (517 mbar)	150 psi (10.3 bar)		
3	40 psi (2.76 bar)	300 psi (20.7 bar)		

(1) Assumes atmospheric pressure of 14.7 psig.

Output

4 to 20 mA Selectable HART Protocol

Range down

20:1

Load Limitations

Maximum loop resistance is determined by the power supply voltage, as described by the following equation:

Maximum loop resistance = 43.5 (power supply voltage - 10.5)

The Field Communicator requires a minimum loop resistance of 250 Ω for communication.

Power Supply

External power supply required. Transmitter operates on 10.5 to 42.4 Vdc with no load. Reverse polarity protection is standard.

Overpressure Limits

Range	Overpressure limit ⁽¹⁾
1	120 psi (8.3 bar)
2	300 psi (20.7 bar)
3	600 psi (41.4 bar)

(1) Overpressure limit is dependent on the clamp/pressure adapter or sensor rating (whichever is lower).

Temperature Limits

Process -4 to 284 °F (-20 to 140 °C)

Ambient -4 to 185 °F (-20 to 85 °C)

Storage -22 to 185 °F (-30 to 85 °C)

Process temperatures above 185 °F (85 °C) require lowering the ambient limits by a 1.5:1 ratio:

Max. ambient temperature in °F = $\frac{85 - (\text{Process Temp} - 185)}{1.5}$

$$\text{Max. ambient temperature in } ^\circ\text{C} = \frac{85 - (\text{Process Temp} - 85)}{1.5}$$

Humidity Limits

0 to 100 percent relative humidity

Volumetric Displacement

Less than 0.0005 in³ (0.008 cm³)

Turn-on Time

Performance within specifications less than 2.0 seconds after power is applied to the transmitter

Failure Alarm

If self-diagnostics detect a sensor or microprocessor failure, the analog signal is driven either high or low to alert the user. High or low failure mode is user-selectable by a jumper on the transmitter. The values to which the transmitter drives its output in failure mode depend on whether it is factory-configured to standard or NAMUR-compliant operation. The values for each are as follows:

Standard Operation

Linear output: $3.9 \leq I \leq 20.8$

Fail high: $I \geq 21.75 \text{ mA}$

Low: $I \leq 3.75 \text{ mA}$

NAMUR-Compliant Operation

Linear output: $3.8 \leq I \leq 20.5$

Fail high: $I \geq 22.5 \text{ mA}$

Low: $I \leq 3.6 \text{ mA}$

Transmitter Security

Activating the transmitter security function prevents changes to the transmitter configuration, including local zero and span adjustments. Security is activated by an internal jumper.

Performance specifications

Zero-based spans, reference conditions, and 316 SST isolating diaphragm

Reference Accuracy

±0.20 percent of calibrated span. Includes combined effects of linearity, hysteresis, and repeatability.

High accuracy (P8) option:

±0.10 percent of calibrated span to 10:1 turndown

Ambient temperature effect per 50°F (28°C)

±(0.15 percent URL + 0.15 percent span) from 1:1 to 20:1

Stability

±0.10 percent of URL for one year, reference stability

Time Response

Total response time 145 ms (Nominal total response time at 75 °F (24 °C) reference conditions.)

Update rate 22 times per second

Vibration Effect

Less than ±0.1 percent of upper range limit when subjected to vibration of peak to peak constant displacement of 4 mm (5 to 15 Hz) and constant acceleration of 2 g (15 to 150 Hz) and 1 g (150 to 2000 Hz)

Power Supply Effect

Less than ± 0.005 percent of calibrated span per volt

Electromagnetic compatibility (EMC)

Meets all industrial environment requirements of EN61326 and NAMUR NE-21. Maximum deviation < 1 percent Span during EMC disturbance.

Note

During surge event, device may exceed maximum EMC deviation limit or reset; however, device will self-recover and return to normal operation within specified start-up time.

Mounting Position Effect

Zero shift of up to 5.0 inH₂O (12.4 mbar), which can be calibrated out. No span effect.

Physical specifications

Material selection

Emerson provides a variety of Rosemount product with various product options and configurations including materials of construction that can be expected to perform well in a wide range of applications. The Rosemount product information presented is intended as a guide for the purchaser to make an appropriate selection for the application. It is the purchaser's sole responsibility to make a careful analysis of all process parameters (such as all chemical components, temperature, pressure, flow rate, abrasives, contaminants, etc.), when specifying product, materials, options and components for the particular application. Emerson is not in a position to evaluate or guarantee the compatibility of the process fluid or other process parameters with the product, options, configuration or materials of construction selected.

Electrical Connection

1/2-14 NPT or M20 3 1.5 conduit entry

Process Wetted Parts

Isolating Diaphragm	316L SST
Process Connector	316L SST
Transmissible Spongiform Encephalopathy (TSE) Declaration	Emerson certifies no process wetted components used in this product contain substances of animal origin. Materials used in the production or processing of wetted components for this products meet the requirements stated in EMA/410/01 Rev. 3 and ISO 2242-1:2015. Wetted components in this product are considered free of TSE.

Non-wetted Parts

Electronics Housing	Low-copper aluminum. Enclosures meet NEMA [®] Type 4X, IP66, and IP68 when properly installed.
Paint	Polyurethane
Cover O-rings	Buna-N
Paint	Polyurethane
Fill Fluid	Neobee M-20
Weight	Approximately 2.74 lb (1.24 kg)

Product Certifications

For product certification information, refer to Quick Start Guide: [Rosemount™ 2088, 2090P, and 2090F Pressure Transmitters](#).

Dimensional drawings

Figure 1: Rosemount 2090F

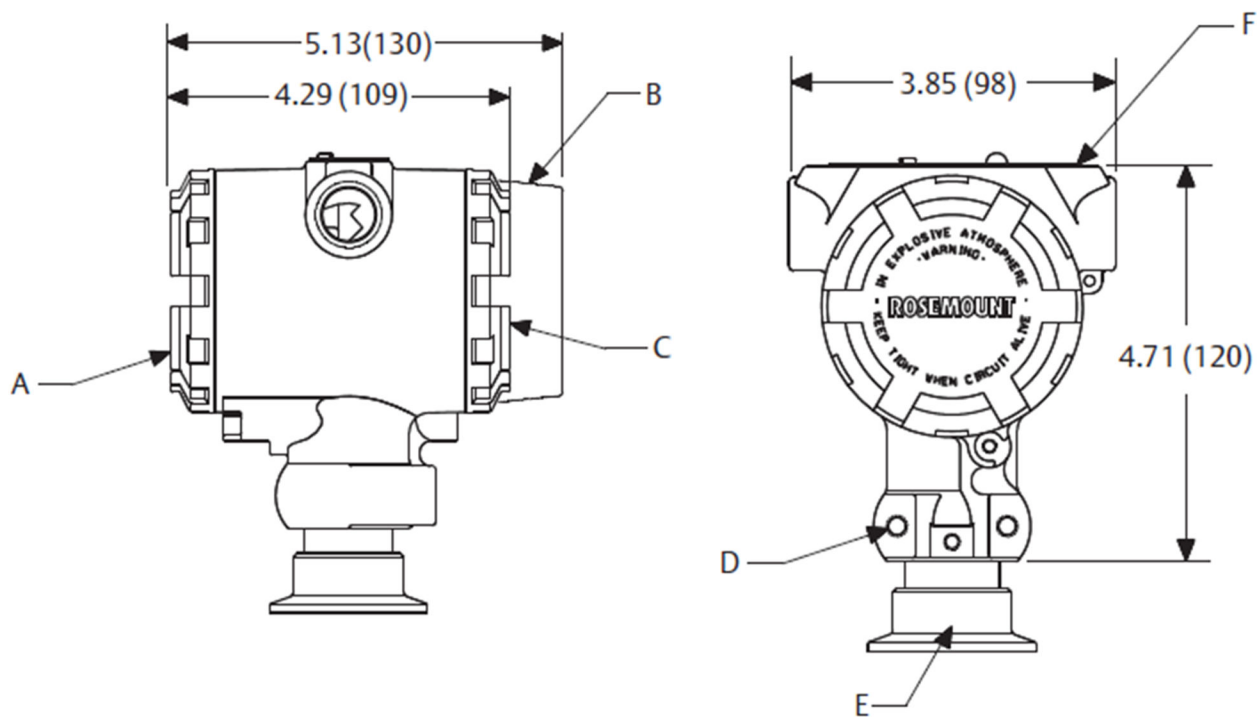

- A. Terminal connection side
- B. Optional display
- C. Transmitter circuitry side
- D. 2 X 1/4-20 UNC-2BX depth 0.60 mounting holes
- E. 1 1/2- or 2-in. Tri Clamp connection
- F. Certification tag

Note

M20 X 1.5 female is also available as option.

Dimensions are in inches (millimeters).

For more information: [Emerson.com/global](https://emerson.com/global)

©2025 Emerson. All rights reserved.

Emerson Terms and Conditions of Sale are available upon request. The Emerson logo is a trademark and service mark of Emerson Electric Co. Rosemount is a mark of one of the Emerson family of companies. All other marks are the property of their respective owners.

ROSEMOUNT™

