

Fisher™ Vee-Ball™ V150, V200 and V300

Rotary Control Valves



General Application

This bulletin covers the DN 25 through 600 / NPS 1 through 24 V150, V200 and V300 Vee-Ball control valves. The Vee-Ball valve combines globe valve ruggedness with the efficiency of a rotary valve. The Vee-Ball valve is a segmented ball valve which features a contoured segmented V-Notch ball. A shearing action between the V-notch ball and the ball seal (Figure 2) promotes smooth, nonclogging operation. The unrestricted straight-through flow design provides high capacity for gas, steam, liquids and fibrous slurries.

V150, V200 and V300 valves mate with a variety of ASME raised face flanges, as well as with EN flanges (see Specifications).

To meet specific application requirements, a variety of metal and soft ball seal materials are available. A splined drive shaft combines with a variety of power operated and manual actuators to provide reliable, high-performance throttling or on-off operation for many different applications in the process industries.

Features

- **Trim Versatility** — Trim components are interchangeable between V150, V200 and V300 valves. This feature allows you to reduce your spare parts inventory and maintenance procedures. The seal assembly can be changed without removing the actuator or without removing the ball from the valve body.
- **Easy Installation** — Flanged body design of the V150 and V300 eliminates exposed line flange bolting, reduces alignment and installation time and promotes secure valve installations and piping integrity. The V200 is available with flanges in NPS 2 through 8.
- **Application Versatility** — The valves are available with ISA S75.08.02 and IEC 534-3-2 face-to-face dimensions as a standard construction and optional ASME B16.10 short face-to-face dimensions. IEC 534.3.2 face-to-face dimensions are equivalent to S75.08.02 face-to-face dimensions.

Figure 1. Fisher Vee-Ball V150 and V200



X0187-1

NPS 3 V150 WITH FISHER 2052 ACTUATOR AND FIELDVUE™ DVC6200 DIGITAL VALVE CONTROLLER



X1800

NPS 16 V150 WITH OPTIONAL CAVITROL™ HEX ANTI-CAVITATION TRIM AND FISHER 1061 ACTUATOR WITH DVC6200



X0337-1

NPS 3 V200 WITH FISHER 2052 ACTUATOR AND DVC6200

- **Long Service Life** — The solid HD ball seal (Figures 2 and 3) construction provides long service life in demanding applications. The constant wiping action of the seal across the ball's sealing surface prevents scale and sludge buildup and provides excellent service on steam, gases, slurries and various liquid applications.
- **Excellent Flow Control** — Precise contouring of the Vee-Ball provides a modified equal percentage flow characteristic. For very precise control of low flow rates, the Micro-Notch option is available on the NPS 1 valve. See the Micro-Notch Construction section of this bulletin for more information.
- **Sour Service Capability** — Materials are available for applications involving sour liquids and gases. These constructions comply with NACE MR0175-2002, MR0175-2003, MR0103 and MR0175/ISO 15156.
- **Smooth Valve Operation** — Precision machined parts and pressure balanced seal designs allow smooth, precise movement of the ball.
- **Quick and Easy Maintenance** — Ball seal inspection and replacement is done at the valve body inlet without removing the actuator or disassembling the valve. Valve maintenance requires no special tools.
- **Structural Integrity** — One-piece valve body improves structural integrity of the pressure boundary by eliminating leak paths that could be caused by the gaskets in two-piece, bolted valve designs.
- **Exceptional Environmental Capabilities** — The optional ENVIRO-SEAL packing systems are designed with very smooth shaft surfaces and live loading to provide exceptional sealing. The seal of the ENVIRO-SEAL system can restrict emissions to less than the EPA (Environmental Protection Agency) limit of 100 ppm (parts per million).
- **Severe Service Trim Options** — Combine the efficiency of a rotary valve with the energy absorbing capability of special trims to provide improved performance for demanding applications such as cavitation or excessive noise.

Table 1. Specifications

Valve Sizes	Maximum Shutoff Pressure/Temperature Ratings ⁽¹⁾
See Table 2	Composition (Fisher TCM Plus or TCM Ultra), Flat Metal (NPS 3 through 12 valves only), HD and High Temperature HD Metal Ball Seals and Flow Ring: See Table 10.
Valve End Connection Styles	Shutoff Classification ⁽¹⁾
<p>V150: Flanged valves that mate with CL150 raised-face flanges and EN 1092-1 Type B raised-face and Type F Recess.</p> <p>Flangeless valve option for NPS 24 that mates with CL150 raised-face flanges.</p> <p>V200: Flangeless (all sizes) and flanged valves that mate with CL600 raised-face flanges (NPS 2 to 8)</p> <p>V300: Flanged valves that mate with CL300 raised-face flanges and EN 1092-1 Type B raised-face and Type F Recess.</p> <p>Flangeless valve option for NPS 24 that mates with CL300 raised-face flanges.</p>	<p>Fisher TCM Plus or Ultra Ball Seal (Forward Flow): Class VI per ANSI/FCI 70-2 and per IEC 60534-4,</p> <p>Flat Metal Ball Seal for NPS 3 through 12 only (Forward Flow): Class IV per ANSI/FCI 70-2 and per IEC 60534-4,</p> <p>HD (Heavy Duty) Ball Seal (Bidirectional Flow): 0.01% of valve capacity; Class IV per ANSI/FCI 70-2 and IEC 60534-4; Maximum allowable pressure drop in reverse flow is 6.9 bar / 100 psi;</p> <p>High Temperature HD (Heavy Duty) Ball Seal (Bidirectional Flow): Class III per ANSI/FCI 70-2 and IEC 60534-4</p> <p>Flow Ring Construction (Bidirectional Flow): 5% of valve capacity at full travel</p> <p>Micro-Notch Ball with HD Seal: 4 SCFH (Leakage rate equivalent to Class IV for standard ball. This is based on the capacity of a standard ball.)</p>
Maximum Inlet Pressures ⁽¹⁾	
<p>Consistent with pressure-temperature ratings per ASME B16.34 and EN12516-1 for the body materials shown in Table 2.</p> <p>Specific to CW2M body material, refer to the pressure-temperature ratings shown in Table 8.</p> <p>Do not exceed the material temperature capabilities shown below or the allowable pressure drop as shown in Tables 9 and 10.</p>	

- continued -

Table 1. Specifications (continued)

Construction Materials	Flow Coefficients, Flow Coefficient Ratio ⁽³⁾ and Noise Levels
See Tables 6 and 7	See Fisher Catalog 12
Temperature Capabilities ^(1,2)	Maximum Ball Rotation
Composition Seals Fisher TCM Plus: -46 to 232°C / -50 to 450°F Fisher TCM Ultra: -46 to 260°C / -50 to 500°F HD Metal Seals: -46 to 288°C / -50 to 550°F PEEK HD Seal: -46 to 232°C / -50 to 450°F High Temperature HD Metal Seal: 288 to 427°C / 550 to 800°F. Contact your Emerson sales office if higher temperatures are required. Ceramic Micro-Notch Ball: -46 to 93°C / -50 to 200°F ⁽⁴⁾ Flow Ring or Flat Metal Seal: -198 to 425°C / -325 to 800°F PEEK/PTFE Bearings: -198 to 260°C / -325 to 500°F	90 degrees Actuator Mounting Standard actuator mounting is on the right-hand side, as viewed from the valve inlet. The standard ball design and actuator action is counter-clockwise to close (CCW) so the ball will rotate to the top of the valve body when open for a horizontal pipe run with the valve shaft positioned horizontal. Left-hand actuator mounting with CCW action is an option. Left-hand (optional) actuator mounting with a special clockwise to close (CW) ball design and actuator action is also available to allow the ball to rotate to the top of the valve body. ⁽⁵⁾
Packing Constructions	Valve/Actuator Action
PTFE V-ring: -46 to 232°C / -50 to 450°F Graphite: -198 to 538°C / -325 to 1000°F ENVIRO-SEAL™ Single PTFE V-ring: -46 to 232°C / -50 to 450°F (for 100 ppm service requirements) ENVIRO-SEAL Graphite: -7 to 316°C / 20 to 600°F (for 100 ppm service requirements). This packing arrangement can be used to 371°C / 700°F for non-environmental service.	With diaphragm or piston rotary actuator, the valve is field-reversible between PDT or PDTO: ■ push-down-to-close (extending actuator rod closes valve) and ■ push-down-to-open (extending actuator rod opens valve)
Flow Characteristic	Approximate Weight
Modified equal percentage	See Table 3
Dimensions	Options
See Figures 14, 15 and 17 for dimensions	<ul style="list-style-type: none"> ■ Pipe plug at end of follower shaft for all sizes ■ Line flange bolting ■ Materials that are compatible with sour service ■ Alloy construction materials ■ ENVIRO-SEAL packing system: See Figure 13 and ENVIRO-SEAL Packing Systems for Rotary Valves Bulletin (D101638X012) for more information ■ Micro-Notch construction for NPS 1 valves (see Micro-Notch Construction section) ■ Alloy trim material ■ Chrome Carbide coated internals (NPS 2 through 12) ■ Rotary attenuator to reduce aerodynamic noise and cavitation effects ■ Double D, Square and Keyed shaft options ■ Cavitrol Hex anti-cavitation trim ■ NXV Whisper Trim™ for aerodynamic noise reduction
Face-to-Face Dimensions	
<ul style="list-style-type: none"> ■ Standard Face-to-Face dimensions comply with ISA S75.08.02 ■ ASME B16.10 short face-to-face dimensions are available as an option for NPS 1 through 12 valves. Note that ASME B16.10 short dimensions are longer than ISA S75.08.02. See Figure 18 for dimensions ■ Short face-to-face dimensions are available for NPS 24 V150 and V300 valves with the flangeless option 	
Standard Flow Direction	
Forward (into the convex face of the V-notch ball)	
1. The pressure/temperature limits in this bulletin and any applicable code or standard limitation, should not be exceeded. 2. Additional limits are shown in Tables 8, 9 and 10. 3. Ratio of maximum flow coefficients to minimum usable flow coefficient can also be called rangeability. 4. For the CG8M and alloy 6 Micro-Notch constructions, pressure and temperature capabilities are the same as for standard constructions. 5. The special clockwise to close (CW) action ball design is not available for the Micro-Notch, Macro-Notch and Micro-Scratch constructions.	

Table 2. Valve Body Materials, End Connections and Ratings

VALVE DESIGN	VALVE BODY MATERIAL	SIZE	RATINGS
		NPS / DN	ASME / PN
V150	WCC	NPS 1, 1-1/2, 2, 3, 4, 6, 8, 10, 12, 14, 16, 20, 24x20 ⁽⁵⁾ , 24	CL150
	WCC/1.0619 ⁽¹⁾	DN 80, 100, 150	PN 10 to 16
		DN 200, 250, 300	PN 10 or PN 16
	LCC	NPS 1, 1-1/2, 2, 3, 4, 6, 8, 10, 12	CL150
		DN 80, 100, 150	PN 10 to 16
		DN 200, 250, 300	PN 10 or PN 16
	CF3M ⁽²⁾ , CF8M/1.4408 ⁽²⁾	NPS 1, 1-1/2, 2, 3, 4, 6, 8, 10, 12	CL150
	CF3M/1.4409 ⁽¹⁾ CF8M/1.4408 ⁽¹⁾	DN 80, 100, 150	PN 10 to 16
		DN 200, 250, 300	PN 10 or PN 16
	R50550	NPS 1, 1-1/2, 2, 3, 4, 6	CL150
	CG8M	NPS 1, 1-1/2, 2, 3, 4, 6, 8, 10, 12, 14, 16, 20, 24x20 ⁽⁵⁾ , 24	
	CW2M	NPS 1, 1-1/2, 2, 3, 4, 6, 8, 10, 12	
	M35-2	NPS 1, 1-1/2, 2, 3, 4, 6, 8	
	CD3MN ⁽³⁾	NPS 1, 1-1/2, 2, 3, 4, 6, 8, 10, 12	
CD3MWCuN ⁽³⁾	NPS 1, 1-1/2, 2, 3, 4, 6, 8, 10, 12		
CK3MCuN	NPS 1, 1-1/2, 2, 3, 4, 6, 8, 10, 12		
V200 ⁽⁴⁾	WCC, LCC, CG8M or CF3M ⁽²⁾	NPS 1, 1-1/2, 2	
		NPS 3, 4	CL150 and CL300/ 600 flangeless
		NPS 6, 8	CL150/300 and CL600 flangeless
		NPS 10	CL150/300/CL600 flangeless
	WCC, LCC or CG8M	NPS 2, 3, 4, 6, 8, 10	CL600
	WCC/1.0609 ⁽¹⁾	NPS 2, 3, 4, 6, 8, 10	CL600
	CF8M/1.4408 ⁽²⁾	DN 50, 80, 100, 150, 200	PN 63 to 100
	CW2M, M35-2 or CK3MCuN	NPS 1, 1-1/2, 2, 3, 4, 6, 8	CL150/300/600 flangeless
	CK3MCuN	NPS 10	CL150 flangeless

- continued -

Table 2. Valve Body Materials, End Connections and Ratings (continued)

VALVE DESIGN	VALVE BODY MATERIAL	SIZE	RATINGS
		NPS / DN	ASME / PN
V300	WCC	NPS 1, 1-1/2, 2, 3, 4, 6, 8, 10, 12, 14, 16, 20, 24	CL300
	WCC/1.0619 ⁽¹⁾	DN 25, 40, 50	PN 10 to 40
		DN 80, 100, 150	PN 25 to 40
		DN 200, 250, 300	PN 25 or PN 40
	LCC	NPS 1, 1-1/2, 2, 3, 4, 6, 8, 10, 12	CL300
		DN 25, 40, 50	PN 10 to 40
		DN 80, 100, 150	PN 25 to 40
	CF3M ⁽²⁾ CF8M/1.4408 ⁽²⁾	NPS 1, 1-1/2, 2, 3, 4, 6, 8, 10, 12	CL300
		DN 25, 40, 50	PN 10 to 40
		DN 80, 100, 150	PN 25 to 40
	R50550	NPS 1, 1-1/2, 2, 3, 4	CL300
		DN 200, 250, 300	PN 25 or PN 40
	CF3M/1.4409 ⁽¹⁾ CF8M/1.4408 ⁽¹⁾	NPS 1, 1-1/2, 2, 3, 4, 6, 8, 10, 12, 14, 16, 20, 24	CL300
		NPS 1, 1-1/2, 2, 3, 4, 6, 8	
		NPS 1, 1-1/2, 2, 3, 4, 6, 8	
		NPS 1, 1-1/2, 2, 3, 4, 6, 8, 10, 12	
NPS 1, 1-1/2, 2, 3, 4, 6, 8, 10, 12			
NPS 1, 1-1/2, 2, 3, 4, 6, 8, 10, 12			
NPS 1, 1-1/2, 2, 3, 4, 6, 8, 10, 12			

1. WCC and EN Stl 1.0619 are dual certified. CF3M and EN SST 1.4409 are dual certified. CF8M and EN SST 1.4408 are dual certified.
 2. CF3M is offered in Europe and Asia Pacific. CF8M / 1.4408 is only offered in Europe.
 3. NORSOK compliant materials available upon request.
 4. Flangeless V200 assemblies mate with raised-face flanges.
 5. Valve body mates with NPS 24 ASME CL150 flanges. Internal based on NPS 20 valve design.

Figure 2. Vee-Ball Construction Features, Seals (Fisher V150 Shown)

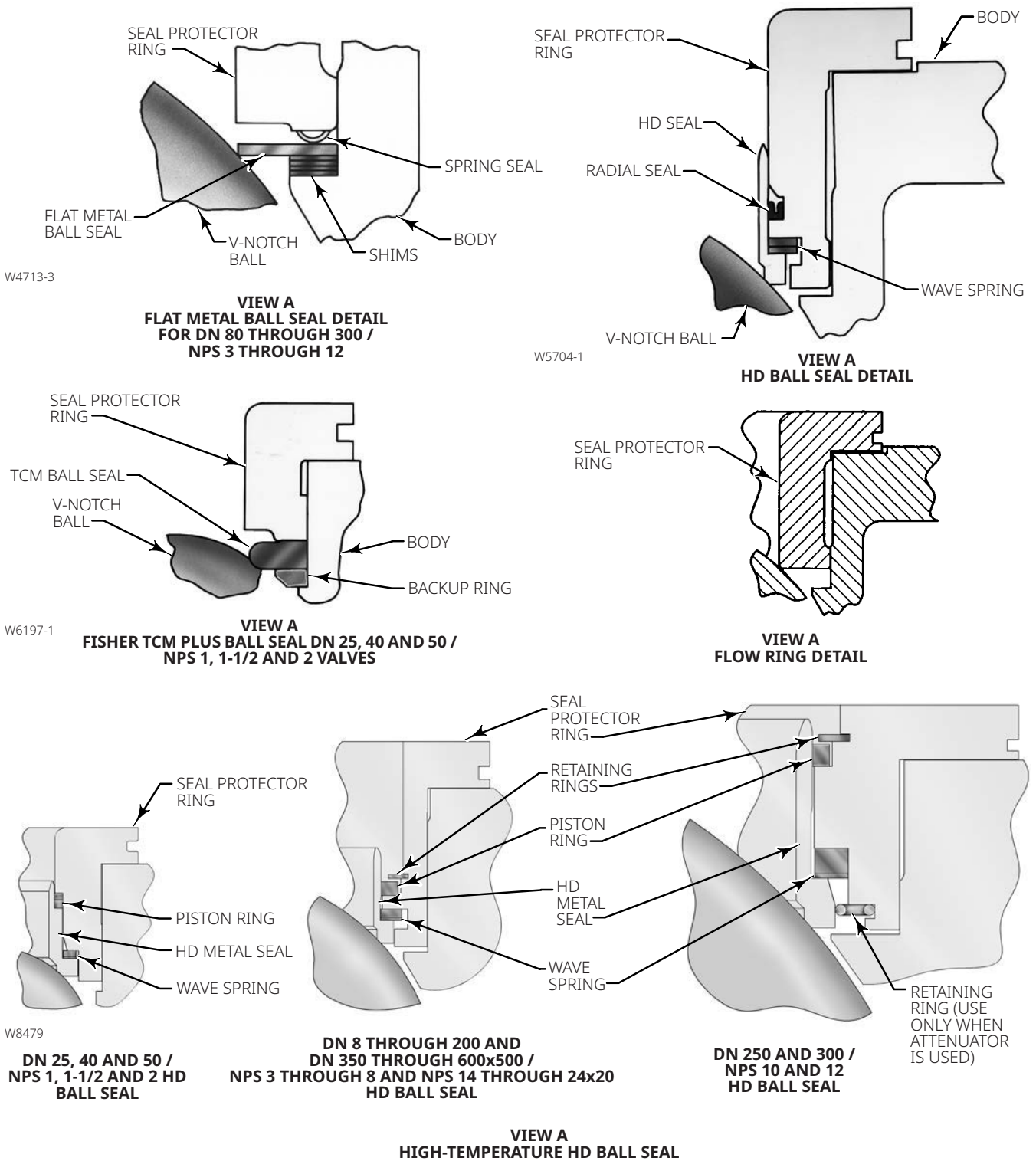
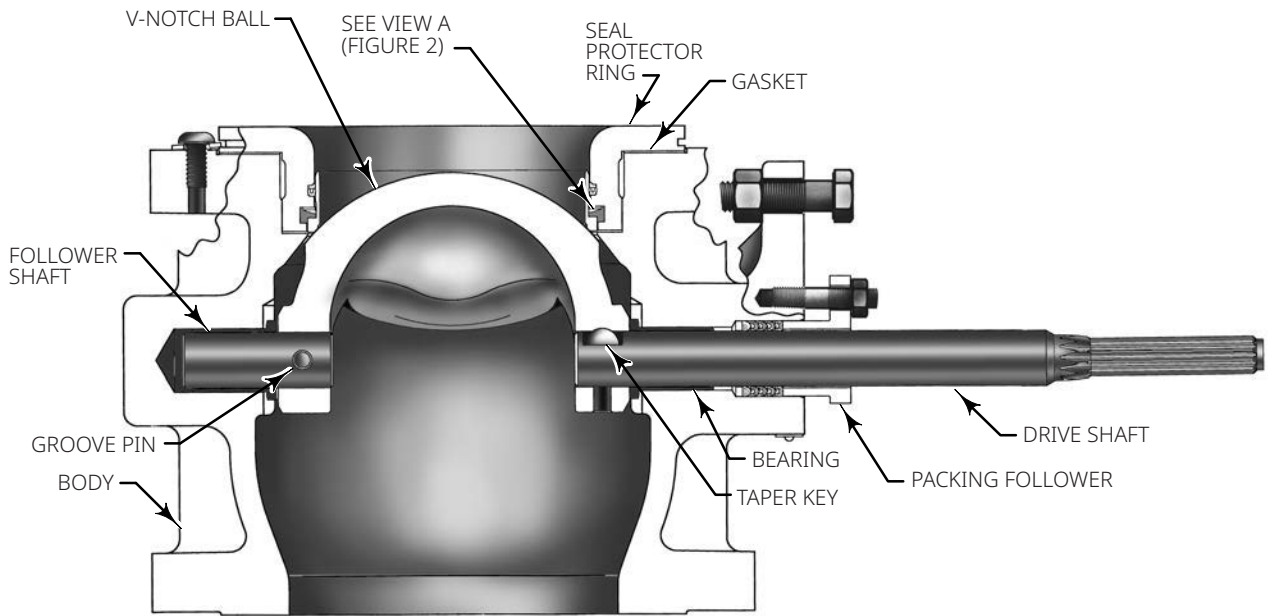
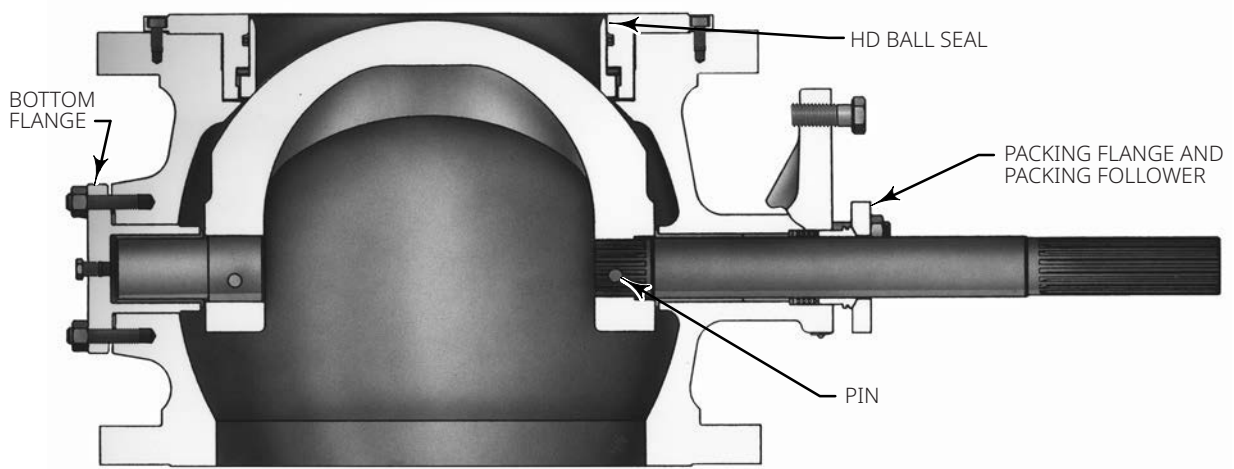

Figure 3. Vee-Ball Construction Features (Fisher V150 Shown)



W7435

**DN 80 THROUGH 300 /
NPS 3 THROUGH 12 VALVES
(HD BALL SEAL SHOWN)**



W6099-1

**DN 350, 400, 500 AND 600 /
NPS 14, 16, 20 AND 24 VALVES
(HD BALL SEAL)**

Table 3. Valve Weights, Approximate

VALVE SIZE		V150		V200		V300	
DN	NPS	kg	lbs	kg	lbs	kg	lbs
25	1	5.6	13	4.5	10	8	17
40	1-1/2	8.2	19	6.4	14	12	27
50	2	9.1	21	10	23	17	38
80	3	13	43	15	34	28	61
100	4	26	57	22	48	37	81
150	6	42	93	36	80	60	133
200	8	72	158	62	136	103	226
250	10	107	235	114	252	200	440
300	12	157	347	---	---	293	645
350	14	247	545	---	---	374	825
400	16	333	735	---	---	510	1125
500	20	524	1155	---	---	755	1661
600x500	24x20	757	1666	---	---	---	---
600	24	965	2122	---	---	1308	2877
600 ⁽¹⁾	24 ⁽¹⁾	798	1755	---	---	898	1975

1. Flangeless valve option.

Series B

NPS 3 through 12 have been changed to reduce parts and to improve control performance. The V-notch Ball now resembles the NPS 14 through 24 V-notch Ball. The pressed-in bushings have been eliminated, as well as the thrust washer.

Micro-Notch Construction

For very precise control of low flow rates, the Micro-Notch construction (see Figure 4) is available on DN 25 / NPS 1 valves. Three Micro-Notch ball materials are available: chrome-plated CG8M (317 stainless steel), solid alloy 6 and solid VTC ceramic. A VTC ceramic HD seal is standard with the VTC ceramic ball. For the CG8M and alloy 6 constructions, pressure and temperature capabilities are the same as for standard constructions. For the ceramic construction, maximum temperature is 93°C / 200°F.

For further information, please refer to the Fisher Vee-Ball V150, V200 and V300 Rotary Control Valves NPS 1 through 12 Instruction Manual (D101554X012).

In addition to the standard Micro-Notch offering, options are available in both low (Micro-Scratch) and high (Macro-Notch) flow construction. Contact your Emerson sales office for more information.

Figure 4. Typical Micro-Notch Ball and Shaft

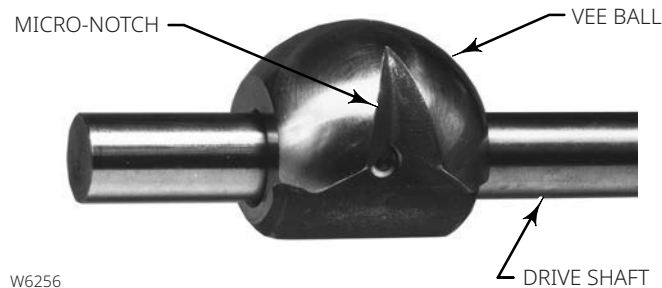

Severe Service Trims

Fisher Vee-Ball Series valves (V150, V200 flanged and flangeless and V300), with the severe service trims combine the efficiency of a rotary valve with the energy absorbing capability of a special trim to provide improved performance for demanding applications.

- **Rotary Attenuator** — Can be utilized in both liquid and gas service to reduce cavitation and noise effects that cause pipeline vibration.
- **Cavitrol Hex Trim** — Can be utilized in liquid applications where severe cavitation is a challenge.
- **Whisper NXV** — Can be utilized in gas or vapor applications where aerodynamic noise is a concern.
- **Other Considerations** — When a rotary noise attenuator is installed in a Vee-Ball valve, the V-notch is no longer a point of high-velocity erosion. As a result, the CoCr-A V-notch option is not required when a rotary noise attenuator is used. The rotary attenuator and CoCr-A V-notch options are not available together.

Figure 5. Severe Service Trim Valve Characteristics

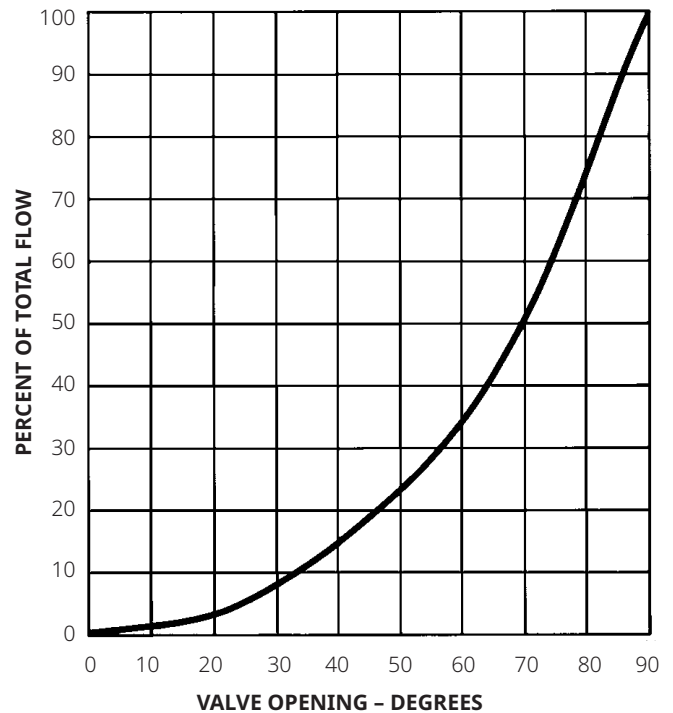

B2365-1

Table 4. Severe Service Trim Benefits Analysis Comparison

Benefits	Typical Competitive Device	Fisher Vee-Ball ⁽¹⁾
Predictable Performance	No	Yes
Superior Attenuation Effect at Critical Opening Position	No	Yes
Maximum Pressure Drop Capability	No	Yes
Heavy Duty, Integrally Welded Attenuator/Ball Assembly	No	Yes
Valve Splined Shaft Connects to Clamped Actuator Lever to Minimize Lost Motion	No	Yes
Superior Soft Seats for Tight Shutoff	No	Yes
Trunnion Mounted Ball for Superior Wear Resistance	Yes	Yes
Heavy Duty Metal Seats for Demanding Applications	Yes	Yes

1. See Figure 5 for valve characteristics.

Rotary Attenuator

The rotary attenuator design can be utilized in both liquid and gas service to reduce cavitation and noise effects that cause pipeline vibration.

Features

- **Trim Versatility** — Trim components are interchangeable for Fisher V150, V200 and V300 valves. This feature allows you to reduce your spare parts inventory and maintenance procedures.
- **Attenuator-Ball Fabrication** — The ball-attenuator construction provides structural integrity because of its rugged fabrication weld.
- **Attenuator Performance** — Up to -10 dBA acoustical attenuation and a $K_c = 1.0$ for hydrodynamics are achievable depending on service conditions.
- **Valve Sizes and End Connection Styles** — NPS 4 through 20 applicable Vee-Ball valves that mate with ASME CL150, CL300 and CL600 raised-face flanges. In addition, DN 100 through DN 300 valve sizes that mate with PN 10, 16, 25 or 40 raised-face flanges.
- **Attenuator Ball Material** — Standard attenuator ball material is CG8M, M35-1, CW2M or CK3McuN. The attenuator will not change the NACE compliance of the Vee-Ball valve.
- **Standard Flow Direction** — Forward flow direction is into the convex face of the V-notch ball. The valve with the attenuator must be placed in the forward flow direction for the attenuator to be effective.
- **Actuator Mounting** — Right-hand or left-hand as viewed from the upstream end of the valve. Counter-clockwise to close and clockwise to close ball designs are available.

Figure 6. Fisher Vee-Ball Series Noise Attenuator Ball

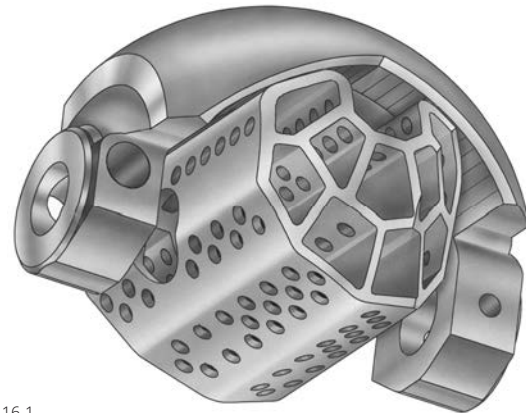

W6116-1

Figure 7. Fisher Vee-Ball Series Rotary Attenuator Construction

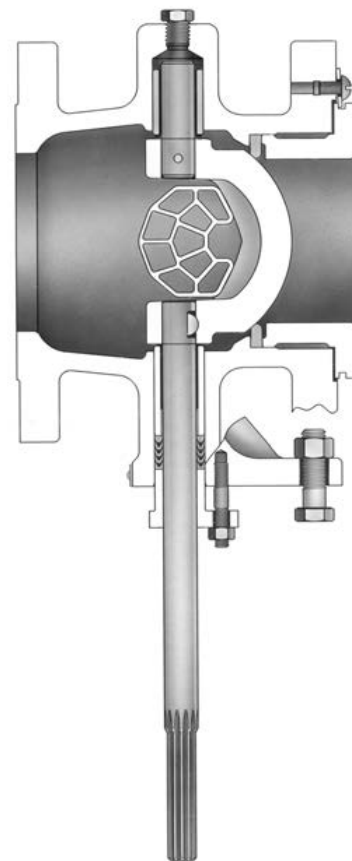

W6129-1

Cavitrol Hex Anti-Cavitation Trim

Designed for the V150, V300 and V200 flanged CL600 valve designs, the Fisher Cavitrol Hex trim option provides improved performance for severe service applications and maintains the efficiency of a rotary valve. The Cavitrol Hex reduces cavitation and noise effects that cause pipeline vibration.

Features

- **Retrofitability** — Convert previously installed Fisher Vee-Ball Series valves with the Cavitrol Hex anti-cavitation trim after minimal modification to the valve body outlet flange.
- **Materials** — Standard Cavitrol Hex trim material is S31603. R31233 material is also available when a harder, more erosion-resistant trim option is required.

- **Performance** — A $K_c=1.0$ for hydrodynamics is achievable at extreme service conditions.
- **Standard Flow Direction** — Forward flow is into the convex face of the V-notch ball. The valve with the Cavitrol Hex trim should be installed in the forward flow direction for the anti-cavitation trim to be most effective.
- **Actuator Mounting** — Right-hand or left-hand as viewed from the upstream end of the valve. Counter-clockwise to close and clockwise to close ball designs are available.
- **Valve Sizes and End Connection Styles** — NPS 4 through 20, applicable Vee-Ball valves that mate with CL150, 300 or 600 raised face flanges.

Figure 8. Fisher NPS 6 V300 Cutaway Image with Optional Cavitrol Hex Anti-Cavitation Trim

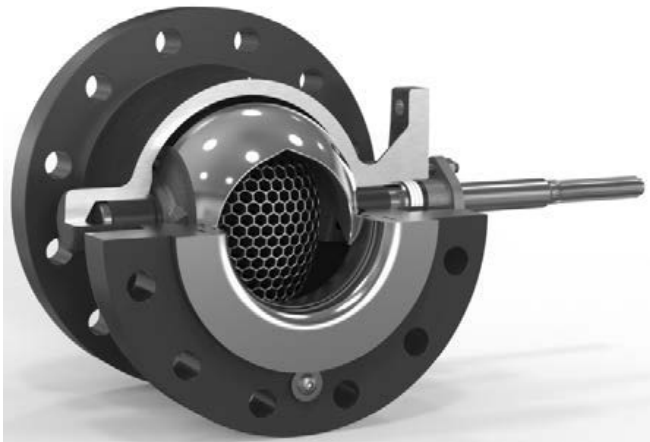

X1561

Figure 9. Fisher NPS 8 V300 Cavitrol Hex Cross Sectional View

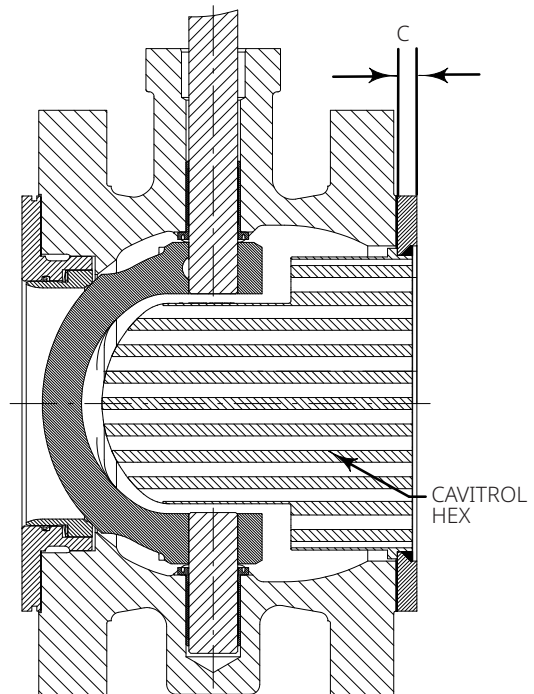

GE96724

Figure 10. Fisher NPS 10 Fisher Cavitrol Hex Trim



X1563

Table 5. Fisher Cavitrol Hex Dimensions and Weight

VALVE SIZE	FLANGE THICKNESS C (ADD TO OVERALL FACE-TO-FACE DIMENSION)		WEIGHT	
	NPS	mm	in.	kg
4	12.7	0.5	3.3	7.3
6	12.7	0.5	7.8	17.3
8	12.7	0.5	12.8	28.3
10	12.7	0.5	24.0	53.1
12	12.7	0.5	35.7	78.8
14	12.7	0.5	44.1	97.3
16	12.7	0.5	63.5	139.9
20	12.7	0.5	111.2	245.1

Figure 11. Fisher Whisper NXV Trim

Whisper NXV Trim

Fisher Vee-Ball Series valves (V150, V200 and V300) with Whisper Trim combines the efficiency of a rotary valve with the acoustical attenuation capability of Whisper technology to provide improved performance in applications where aerodynamic noise is a concern. The Fisher Whisper Trim can be utilized in gas and vapor service to reduce noise effects that cause pipeline vibration.

The noise reduction technology includes the Vee-Ball Series splined drive shaft, which combines with a variety of power operated and manual actuators to provide reliable, high-performance throttling or on-off operation for many different applications in the process industries.

The Whisper NXV is not intended for liquid applications. If the process generates condensation that can induce water hammer, consult your [Emerson sales office](#).

Features

- **Whisper NXV Fabrication** — The additively manufactured attenuator features a rugged fabrication weld to provide structural integrity with the ball.
- **Whisper NXV Performance** — Up to -20 dBA acoustical attenuation is achievable depending on service conditions.
- **Excellent Flow Characteristic** — Precise contouring of the V-notch ball provides an approximately equal percentage flow characteristic.
- **Valve Sizes and End Connections** — NPS 4 through 16 valves that mate with CL150 through CL600 raised-face flanges. In addition, DN 100 through DN 300 valve sizes that mate with PN 10, 16, 25 or 40 raised-face flanges.

Figure 12. Fisher Vee-Ball Series Whisper NXV Construction

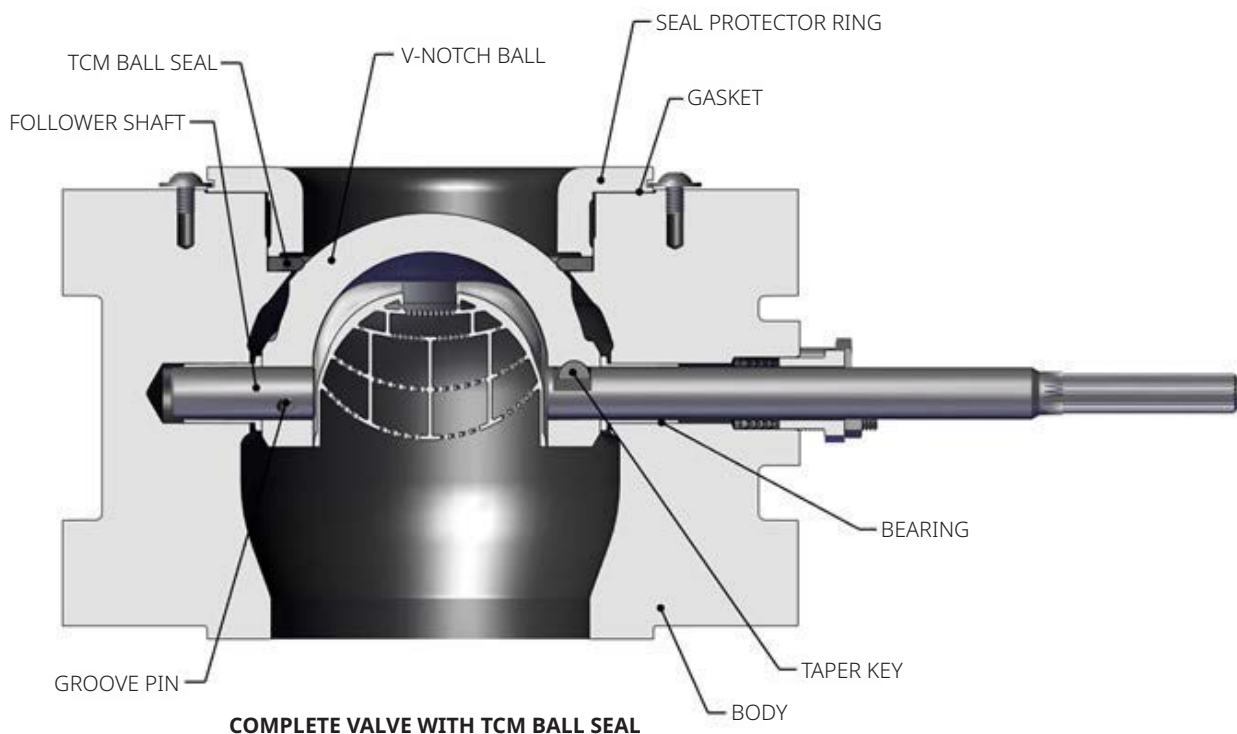

X1960

Table 6. Materials of Construction for DN 25 through 300 / NPS 1 through 12 Valves

Part		Material
Valve Body and Seal, Protector Ring or Flow Ring		WCC steel (EN 1.0619), CG8M (317 Stainless steel), R50550 ⁽¹⁰⁾ , CF3M ⁽¹⁾ (316L Stainless steel EN 1.4409 or optional or CF8M (316 Stainless steel EN 1.4408) EN 1.4581), CD3MN, CD3MWCuN, CW2M (CW2M valve available with Fisher TCM Plus seal only), M35-2 or CK3MCuN
Backup Ring (DN 25, 40 and 50 / NPS 1, 1-1/2 and 2 only)		CG8M, CF3M ⁽¹⁾ , R50550 or CW2M
Segmented V-Notch Ball		CG8M, R50550, CF3M, CW2M, Chromium-plated CF3M, Chromium-plated CG8M, Chromium-plated CG8M with alloy 6 notch, Chromium-plated CF3M with alloy 6 notch, Chromium-plated CD3MN, Chromium-plated CD3MWCuN, M35-1 or CK3MCuN
Seal	Fisher TCM	Fisher TCM Plus and Fisher TCM Ultra
	Flat Metal Seal, Shims and Spring Seal ⁽⁷⁾	Spring Tempered S31600 (316 SST) or Spring Tempered S30200 (302 SST) for NPS 12 valves only
	HD (Heavy-Duty) Ball Seal	CF10SMnN ⁽²⁾ , CD7MCuN ⁽³⁾ (Alloy 255 duplex Stainless steel) or R30006 (Alloy 6)
	High Temperature HD Seal	R30006 (Alloy 6)

- continued -

Table 6. Materials of Construction for DN 25 through 300 / NPS 1 through 12 Valves (continued)

Part	Material
Wave Spring (use with HD seal)	N07750
HD Seal Radial Seal	Graphite reinforced PTFE
High Temp HD Seal Piston Ring	Graphite FMS 17F39
Bearings	PEEK ⁽⁴⁾ /Carbon-filled PTFE liner, S31603 Nitride, R30006 (Alloy 6), Silver-plated R30006, N10276 with Carbon-filled PTFE liner or N10276 with glass-filled PTFE liner R50400 PTFE/Carbon liner (through NPS 6), R50400 PTFE/Glass liner (through NPS 6)
Seal Retainer Gasket	Laminated Graphite
Packing	PTFE V-ring with one Carbon-filled PTFE ring ⁽⁵⁾ , PTFE V-ring, Graphite ribbon, ENVIRO-SEAL PTFE or ENVIRO-SEAL Graphite
Shafts	S20910, S17400 (17-4PH SST), N10276, N05500, S31254 ⁽⁸⁾ , R50550 or S32760 ⁽⁸⁾
Groove Pin	R50550, S31600 or N10276
Taper Key	R50550, R30006 ⁽⁶⁾ , S20910 or N10276
Taper Pin (DN 25, 40 and 50 / NPS 1, 1-1/2 and 2 only)	R50550, S20910 or N10276
Pipe Plug (Optional)	S31600 N10276 or S31603 (316L SST)
Seal Retainer Screws and Washers	Stainless steel
Packing Follower and Packing Box Ring	R50550, CF8M (316 SST), N10276, S312254 or N10276 with separate S31600 packing box flange
Actuator Mounting Bolts and Nuts	Grade 5 steel or strain-hardened B8M Stainless steel
Spacer and Bushing	S31700, N10276 or S31603
Packing Follower Bolting and Optional Line Bolting	SA-193-B7, SA-193-B7M or strain-hardened SA-193-B8M
Attenuator ⁽⁹⁾	CG8M, M35-1, CW2M or CK3MCuN
Cavitrol Hex	S31603 or R31233
Whisper NXV Trim	S31603
<p>1. CF3M and CF8M are available in all areas as a special order and are offered as standard material in Europe. 2. Recommended for lubricated and non-lubricated service and where corrosion properties similar to 304 Stainless steel are acceptable. 3. Recommended for lubricated service and where corrosion properties equal to or better than 317 Stainless steel are required. 4. PEEK is poly-ether-ether-ketone. 5. The Carbon-filled PTFE ring is used for grounding. 6. Standard material offered in North America. 7. Offered for lubricated service only. 8. S31254 and S32760 shafts may cause the valve to be derated. Contact your Emerson sales office. 9. Attenuator material will match segmented V-Notch ball material. 10. R50550 is available with TCM seat. For other seal availability, contact your Emerson sales office.</p>	

Table 7. Materials of Construction for DN 350, 400, 500 and up to 600 / NPS 14, 16, 20 and 24 Valves

Part		Material
Valve Body, Seal Protector Ring and Flow Ring		WCC steel or CG8M (317 Stainless steel)
Segmented V-Notch Ball		Chromium-plated CG8M, CG8M, Chromium-plated CG8M with Alloy 6 notch
Ball Seal	Fisher TCM	Fisher TCM Plus and Fisher TCM Ultra
	HD (Heavy-Duty Metal)	CF10SMnN ⁽¹⁾ , CD7MCuM ⁽²⁾ (Alloy 225 duplex Stainless steel) or CG8M/CoCr-A
Wave Spring (use with HD seal)		N07750
Radial Seal (use with HD seal)		PTFE with N10276 spring
Bearings		PEEK/PTFE ⁽³⁾ , S44004 (440C Stainless steel – use with S17400 [17-4PH Stainless steel] shafts), alloy 6B and Silver plated alloy 6B
Thrust Washer (use with metal bearings)		Alloy 6B
Seal Retainer Gasket		Laminated Graphite
Packing		PTFE V-ring with one conductive V-ring ⁽⁴⁾ , PTFE V-ring, Graphite ribbon, ENVIRO-SEAL PTFE or ENVIRO-SEAL Graphite
Shafts		S17400 (17-4 Stainless steel) or S20910
Pins		S20910
Pipe Plug		S31700 (317 Stainless steel)
Packing Follower Bolting		B7M steel or strain-hardened B8M Stainless steel
Retainer Screw		B8M Stainless steel
Packing Follower and Packing Box ring		S31600 (316 Stainless steel)
Packing Flange		Steel or S31600
Actuator Mounting Bolts and Nuts		Grade 5 steel or strain-hardened B8M Stainless steel
Gasket (used with bottom flange)		S31603 (316L Stainless steel) spiral wound
Stud and Hex Nut (used with bottom flange)		B7 steel or strain-hardened B8M Stainless steel
Attenuator		CG8M
Cavitrol Hex		S31603 or R31233
Whisper NXV Trim		S31603
1. Recommended where corrosion properties similar to 304 Stainless steel are acceptable. 2. Recommended for lubricated service and where corrosion properties equal to or better than S31700 Stainless steel. 3. PEEK (Poly-ether-ether-ketone) with PTFE liner. 4. A carbon-filled PTFE ring is used for grounding.		

Figure 13. Typical ENVIRO-SEAL Packing Arrangements

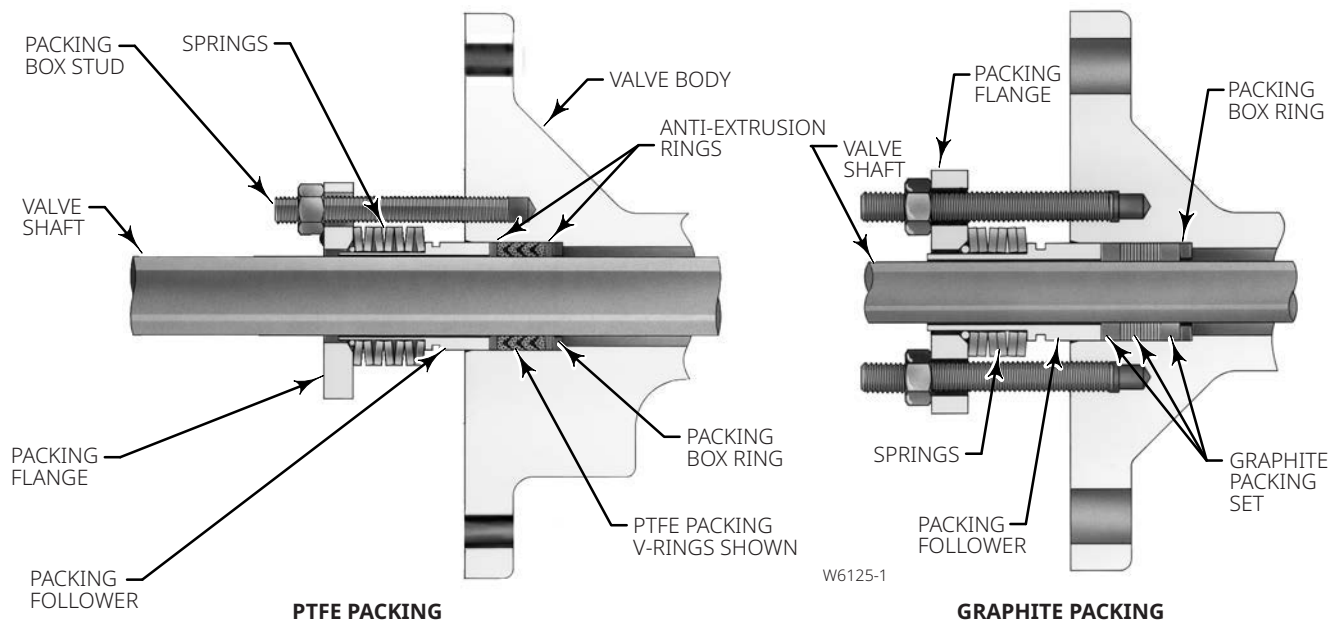

W5806-2

Table 8. Maximum Allowable Inlet Pressure for CW2M Valves

TEMPERATURE	CW2M ⁽¹⁾					
	150 ⁽²⁾	300 ⁽²⁾	PN 10 ⁽²⁾	PN 16 ⁽²⁾	PN 25 ⁽²⁾	PN 40 ⁽²⁾
°C	bar					
-46 to 38	20.0	51.7	10.0	16.0	25.0	40.0
50	19.5	51.7	9.9	15.9	24.8	39.6
100	17.7	51.5	9.4	15.1	23.6	37.8
150	15.8	50.3	9.4	15.1	23.6	37.8
200	13.8	48.3	9.1	14.6	22.9	36.6
232	12.7	47.0	9.1	14.6	22.9	36.6
°F	psi					
-50 to 100	290	750	145	232	362	580
200	260	750	144	230	359	575
300	230	730	137	219	342	548
400	200	700	133	212	331	530
450	185	680	133	212	331	530

1. This material is not listed in EN 12516-1 or ASME B16.34. Also see the Installation section.

2. The designations PN or 150 and 300 are used only to indicate relative pressure-retaining capabilities and are not EN or ASME pressure-temperature rating class designations.

Pressure Drops

Pressure drop limits of any given valve are based on valve body and trim material limits. To find the appropriate pressure drop limitation, choose the desired valve size and temperature range. Then search Table 9 for body limitations and Table 10 for

trim limitations. Information on limits for S31254, CW2M, M35-2, CD3MN, CD3MWCuN and other alloy constructions can be obtained by contacting your [Emerson sales office](#). The lowest number from the tables is the appropriate limit. The tables for both trim and body limits must be consulted.

Table 9. Maximum Allowable Shutoff Pressure Drops (Body Ratings)

(Tables for both trim and body limits must be consulted.)

TEMPERATURE RANGE	PRESSURE CLASS													
	WCC CL150	CF3M CF8M CL150	CG8M CL150	LCC CL150	R50550 CL150	WCC CL300	CF3M CF8M CL300	CG8M CL300	LCC CL300	R50550 CL300	WCC CL600	CF3M CF8M CL600	CG8M CL600	LCC CL600
°C	bar													
-46 to -29	-- (1)	19.0	19.0	20	18.3	-- (1)	49.6	49.6	51.7	47.2	-- (1)	99.3	99.3	103
-29 to 38	20.0	19.0	19.0	20	18.3	51.7	49.6	49.6	51.7	47.2	103	99.3	99.3	103
93	17.9	16.2	16.2	17.9	15.5	51.7	42.7	42.7	51.7	40.7	103	85.5	85.5	103
149	15.9	14.8	14.8	15.9	12.8	50.3	38.6	38.6	50.3	33.0	100	77.2	77.2	100
177	-- (2)	-- (2)	-- (2)	-- (2)	11.7	-- (2)	-- (2)	-- (2)	-- (2)	30.0	-- (2)	-- (2)	-- (2)	-- (2)
204	13.8	13.4	13.4	13.8	10.3	48.6	35.5	35.5	48.6	26.9	97.2	70.6	70.6	97.2
232	12.8	12.8	12.8	12.8	9.3	47.2	34.5	34.5	47.2	24.5	94.5	68.6	68.6	94.5
260	11.7	11.7	11.7	11.7	8.3	45.9	33.1	33.1	45.9	22.1	91.7	65.8	65.8	91.7
316	10.7	10.7	10.7	10.7	7.9	43.8	32.1	32.1	43.8	20.7	87.6	64.1	64.1	87.6
343	9.65	8.62	8.62	9.65	7.2	41.7	31.0	31.0	41.7	19.0	83.4	62.4	62.4	83.4
371	8.62	7.58	7.58	---	---	40.7	30.7	30.7	---	---	81.0	60.0	60.0	---
399	6.55	6.55	6.55	---	---	34.8	29.3	29.3	---	---	69.6	58.9	58.9	---
427	5.52	5.52	5.52	---	---	28.3	29.0	29.0	---	---	56.9	58.3	58.3	---
°F	psi													
-50 to -20	-- (1)	275	275	290	265	-- (1)	720	720	750	695	-- (1)	1440	1440	1500
-20 to 100	290	275	275	290	265	750	720	720	750	695	1500	1440	1440	1500
200	260	235	235	260	225	750	620	620	750	590	1500	1240	1240	1500
300	230	215	215	230	185	730	560	560	730	480	1455	1120	1120	1455
350	-- (2)	-- (2)	-- (2)	-- (2)	170	-- (2)	-- (2)	-- (2)	-- (2)	435	-- (2)	-- (2)	-- (2)	-- (2)
400	200	195	195	200	150	705	515	515	705	390	1410	1025	1025	1410
450	185	185	185	185	135	685	500	500	685	355	1370	995	995	1370
500	170	170	170	170	120	665	480	480	665	320	1330	955	955	1330
550	155	155	155	155	115	635	465	465	635	300	1270	930	930	1270
600	140	140	140	140	105	605	450	450	605	275	1210	905	905	1210
650	125	125	125	125	---	590	445	445	590	---	1175	890	890	1175
700	110	110	110	---	---	570	430	430	---	---	1135	870	870	---
750	95	95	95	---	---	505	425	425	---	---	1010	855	855	---
800	80	80	80	---	---	410	420	420	---	---	825	845	845	---

1. Low temperature for these materials limited to -29°C / -20°F.
2. Refer to ASME B16.34.

Table 10. Maximum Allowable Shutoff Pressure Drops based on Trim (Bearing and Seal)
 (Note: Do not exceed the PN or ASME pressure/temperature rating of the valve or mating flanges.)

BEARING MATERIAL	BALL SEAL	TEMPERATURE RANGE, °C	VALVE SIZE, DN														
			25	40	50	80	100	150	200	250	300	350	400	500 ⁽⁴⁾	600		
			bar														
			Shaft Size, in.														
			1/2	5/8	5/8	3/4	3/4	1	1-1/4	1-1/4	1-1/2	1-3/4	2-1/8x2	2-1/8	2-1/2	3	
PEEK/ PTFE	Fisher TCM Plus or Ultra	-46 to 38	51.7	51.7	51.7	51.7	51.7	51.7	51.7	51.7	40.2	37.6	31.0	23.8	31.0	31.0	31.0
		93	37.9	37.9	37.9	37.9	37.9	37.9	37.9	37.9	37.9	37.6	31.0	23.8	31.0	31.0	31.0
		149	24.1	24.1	24.1	24.1	24.1	24.1	24.1	24.1	24.1	24.1	24.1	23.8	24.1	24.1	24.1
		204	10.3	10.3	10.3	10.3	10.3	10.3	10.3	10.3	10.3	10.3	10.3	10.3	10.3	10.3	10.3
		232	3.45	3.45	3.45	3.45	3.45	3.45	3.45	3.45	3.45	3.45	3.45	3.45	3.44	3.45	3.45
	HD Seal ⁽¹⁾	-46 to 260	51.7	51.7	51.7	51.7	51.7	51.7	51.7	51.7	40.9	38.1	31.0	26.5	31.0	31.0	31.0
	Flat Metal ⁽²⁾	-73 to 260	---	---	---	20.7	20.7	20.7	20.7	20.7	10.3	10.3	---	---	---	---	---
Flow Ring	260	103.4	103.4	103.4	103.4	72.4	75.2	73.8	40.5	37.7	40.5	35.0	48.8	44.7	45.2		
R30006	HD Seal ⁽¹⁾	-46 to 288	51.7	50.0	25.7	17.5	11.0	10.9	11.2	6.14	5.72	6.14	7.52	7.51	6.83	6.76	
	High Temp HD Seal ⁽¹⁾	228 to 427	38.3 ⁽³⁾	37.5 ⁽³⁾	19.3 ⁽³⁾	13.2 ⁽³⁾	8.3 ⁽³⁾	8.2 ⁽³⁾	8.4 ⁽³⁾	4.6 ⁽³⁾	4.3 ⁽³⁾	4.62	5.65	5.65	5.10	---	
	Flat Metal ⁽²⁾	-73 to 427	---	---	---	17.0	10.1	10.7	10.6	5.86	5.52	---	---	---	---	---	
	Flow Ring	427	74.5	49.6	26.8	18.8	10.9	11.2	11.1	6.07	5.65	6.07	7.31	7.30	6.69	6.76	
R30006 Silver Plated	HD Seal ⁽¹⁾	-46 to 288	51.7	51.7	51.7	35.0	22.1	21.8	22.5	12.3	11.4	12.3	13.2	15.0	13.7	13.5	
	High Temp HD Seal ⁽¹⁾	228 to 427	38.3 ⁽³⁾	38.3 ⁽³⁾	38.3 ⁽³⁾	26.3 ⁽³⁾	16.5 ⁽³⁾	16.3 ⁽³⁾	16.9 ⁽³⁾	9.2 ⁽³⁾	8.6 ⁽³⁾	9.16	11.2	11.2	10.2	---	
	Flat Metal ⁽²⁾	-73 to 427	---	---	---	20.7	20.1	20.7	20.7	10.3	10.3	---	---	---	---	---	
	Flow Ring	427	103.4	103.4	53.5	37.6	21.8	22.5	22.2	12.1	11.3	12.1	14.6	14.6	13.4	13.5	
S31603L Nitride	HD Seal ⁽¹⁾	-46 to 288	51.0	51.0	51.0	51.7	36.7	36.3	37.4	20.5	19.1	20.5	25.0	25.0	14.0	22.6	
	High Temp HD Seal ⁽¹⁾	228 to 427	---	---	---	38.3 ⁽³⁾	27.6 ⁽³⁾	27.2 ⁽³⁾	28.1 ⁽³⁾	15.4 ⁽³⁾	14.3 ⁽³⁾	15.3	18.7	18.7	17.0	---	
	Flat Metal ⁽²⁾	-73 to 427	---	---	---	20.7	20.7	20.7	20.7	10.3	10.3	---	---	---	---	---	
	Flow Ring	427	99.3	99.3	88.9	62.7	36.3	37.4	37.0	20.2	18.8	20.2	24.3	24.3	22.3	22.6	
R50400 PTFE or N10276 PTFE	Fisher TCM Plus or Ultra	-46 to 38	51.7	51.7	51.7	51.7	36.75	36.3	37.4	20.5	19.1	20.5	25	25	22.75	---	
		93	37.9	37.9	37.9	37.9	36.75	36.3	37.4	20.5	19.1	20.5	25	25	22.75	---	
		149	24.1	24.1	24.1	24.1	24.1	24.1	24.1	20.5	19.1	20.5	25	25	22.75	---	
		204	10.3	10.3	10.3	10.3	10.3	10.3	10.3	10.3	10.3	10.3	10.3	10.3	10.3	---	
		232	3.45	3.45	3.45	3.45	3.45	3.45	3.45	3.45	3.45	3.45	3.45	3.45	3.45	---	
	Flow Ring	260	103.4	103.4	103.4	103.4	72.4	75.2	73.8	40.5	37.7	40.5	35.0	48.8	44.7	---	

- continued -

Table 10. Maximum Allowable Shutoff Pressure Drops based on Trim (Bearing and Seal) (continued)

(Note: Do not exceed the PN or ASME pressure/temperature rating of the valve or mating flanges.)

BEARING MATERIAL	BALL SEAL	TEMPERATURE RANGE, °F	VALVE SIZE, NPS														
			1	1-1/2	2	3	4	6	8	10	12	14	16	20 ⁽⁴⁾	24		
			psi														
			Shaft Size, in.														
			1/2	5/8	5/8	3/4	3/4	1	1-1/4	1-1/4	1-1/2	1-3/4	2-1/8x2	2-1/8	2-1/2	3	
PEEK/ PTFE	Fisher TCM Plus or Ultra	-50 to 100	750	750	750	750	750	750	750	750	583	545	450	345	450	450	450
		200	550	550	550	550	550	550	550	550	550	545	450	345	450	450	450
		300	350	350	350	350	350	350	350	350	350	350	350	345	350	350	350
		400	150	150	150	150	150	150	150	150	150	150	150	150	150	150	150
		450	50	50	50	50	50	50	50	50	50	50	50	50	50	50	50
	HD Seal ⁽¹⁾	-50 to 500	750	750	750	750	750	750	750	750	593	553	450	384	450	450	450
	Flat Metal ⁽²⁾	-100 to 500	---	---	---	300	300	300	300	300	150	150	---	---	---	---	---
Flow Ring	500	1500	1500	1500	1500	1050	1090	1070	587	547	587	508	708	648	656		
R30006	HD Seal ⁽¹⁾	-50 to 550	750	725	373	254	160	158	163	89	83	89	109	109	99	98	
	High Temp HD Seal ⁽¹⁾	550 to 800	555 ⁽³⁾	544 ⁽³⁾	280 ⁽³⁾	191 ⁽³⁾	120 ⁽³⁾	119 ⁽³⁾	122 ⁽³⁾	67 ⁽³⁾	62 ⁽³⁾	67	82	82	74	---	
	Flat Metal ⁽²⁾	-100 to 800	---	---	---	246	146	155	154	85	80	---	---	---	---	---	
	Flow Ring	800	1080	720	388	273	158	163	161	88	82	88	106	106	97	98	
R30006 Silver Plated	HD Seal ⁽¹⁾	-50 to 550	750	750	750	508	320	316	326	178	166	178	192	218	198	196	
	High Temp HD Seal ⁽¹⁾	550 to 800	555 ⁽³⁾	555 ⁽³⁾	555 ⁽³⁾	381 ⁽³⁾	240 ⁽³⁾	237 ⁽³⁾	245 ⁽³⁾	134 ⁽³⁾	125 ⁽³⁾	133	163	163	148	---	
	Flat Metal ⁽²⁾	-100 to 800	---	---	---	300	292	300	300	150	150	---	---	---	---	---	
	Flow Ring	800	1500	1500	776	546	316	326	322	176	164	176	212	212	194	196	
S31603L Nitride	HD Seal ⁽¹⁾	-50 to 550	740	740	740	750	533	527	543	297	277	297	363	363	203	328	
	High Temp HD Seal ⁽¹⁾	550 to 800	---	---	---	555 ⁽³⁾	400 ⁽³⁾	395 ⁽³⁾	407 ⁽³⁾	223 ⁽³⁾	208 ⁽³⁾	222	272	272	247	---	
	Flat Metal ⁽²⁾	-100 to 800	---	---	---	300	300	300	300	150	150	---	---	---	---	---	
	Flow Ring	800	1440	1440	1290	910	527	543	537	293	273	293	353	353	323	328	
R50400 PTFE or N10276 PTFE	Fisher TCM Plus or Ultra	-50 to 100	750	750	750	750	533	527	543	297	277	297	363	363	330	---	
		200	550	550	550	550	533	527	543	297	277	297	363	363	330	---	
		300	350	350	350	350	350	350	350	297	277	297	363	363	330	---	
		400	150	150	150	150	150	150	150	150	150	150	150	150	150	---	
		450	50	50	50	50	50	50	50	50	50	50	50	50	50	---	
	Flow Ring	500	1500	1500	1500	1500	1050	1090	1070	587	547	587	508	708	648	---	

1. Pressure drops shown for HD seals are for forward flow only. For reverse flow with HD seal, limit pressure drop to 6.9 bar / 100 psig.
 2. Lubricated service only.
 3. Consult your Emerson sales office if higher pressure drops are required.
 4. This column is also appropriate for the DN 600x500 / NPS 24x20.

Table 11. Fisher V150 Dimensions

VALVE SIZE	V150 DIMENSIONS (ISA S75.08.02) ⁽¹⁾											APPROXIMATE WEIGHT
	A ⁽⁵⁾	B	D	G	K	M ⁽³⁾	N ^(3,4)	S Diameter	T	U	W	
DN	mm											kg
25	102	56		83	95	79	73	13				5.9
40	114	62	188	90	121	92	80	15.9 and 15.9 x 12.7	117	---	14.2	8.6
50	124	67		87	127	100	87	15.9 and 15.9 x 12.7				9.5
80	165	79		100	130	106	100	19.1			14.2	19.5
100	194	101	214	133	141	119	100	19.1	152	31.8	14.2	26
150	229	109		151	164	127	114	25.4			14.2	42
200	243	124		184	232	133	127	31.8				72
250	297	147	208	222	260	146	133	31.8	235	46.0	17.5	107
300	338	174		268	303	152	133	38.1				158
350 ⁽²⁾	381	206	356	295	343	152	133	44.5	273	50.8	19.1	248
400 ⁽²⁾	406	229	356	330	365	152	133	54.0	273	50.8	19.1	333
500	508	235	356	406	457	178	159	63.5	337	76.2	22.4	525
600x500	608	373	356	406	457	192	171	63.5	337	76.2	22.4	757
600	610	324	470	500	547	204	191	63.5	533	127	31.8	965
NPS	in.											lbs
1	4.00	2.21		3.19	3.75	3.12	2.88	1/2				13
1-1/2	4.50	2.46	7.38	3.38	4.75	3.62	3.12	5/8 and 5/8 x 1/2	4.62	---	0.56	19
2	4.88	2.63		4.19	5.00	3.94	3.44	5/8 and 5/8 x 1/2				21
3	6.50	3.10		4.62	5.12	4.19	3.94	3/4			0.56	43
4	7.62	3.99	8.44	5.25	5.56	4.69	3.94	3/4	6.00	1.25	0.56	57
6	9.00	4.29		5.94	6.44	5.00	4.50	1			0.56	93
8	9.56	4.88		7.69	9.12	5.25	5.00	1-1/4				158
10	11.69	5.77	8.19	8.75	10.25	5.75	5.25	1-1/4	9.25	1.81	0.69	235
12	13.31	6.87		10.56	11.94	6.00	5.25	1-1/2				347
14 ⁽²⁾	15.00	8.12	14.00	11.62	13.50	6.00	5.25	1-3/4	10.75	2.00	0.75	545
16 ⁽²⁾	16.00	9.00		13.00	14.38	6.00	5.25	2-1/8	10.75	2.00	0.75	735
20	20.00	9.25		16.00	18.00	7.00	6.25	2-1/2	13.25	3.00	0.88	1155
24x20	23.94	14.69		16.00	18.00	7.56	6.75	2-1/2	13.25	3.00	0.88	1666
24	24.00	12.75	18.50	19.70	21.55	8.00	7.50	2-1/2	21.00	5.00	1.25	2122

1. Inlet flange stud bolt length is longer than the standard length specified in ASME B16.5. See dimension M below.
 2. DN 350 and 400 / NPS 14 and 16 valves are available in ASME B16.10 short, only. See dimension A for ASME B16.10 short shown in Figure 18.
 3. Clearance necessary to remove flange bolts.
 4. For valve assemblies with the Cavitrol Hex anti-cavitation trim installed, the required outlet flange bolt length and the clearance necessary to remove the bolt will be 12.7 mm / 1/2 in. longer than dimension N specified. In this case, use dimension M to determine the outlet flange bolt length.
 5. For valve assemblies with Cavitrol Hex anti-cavitation trim installed, dimension A will be 12.7 mm / 1/2 in. larger than specified.

Figure 14. Fisher V150 Dimensions (also see Table 11)

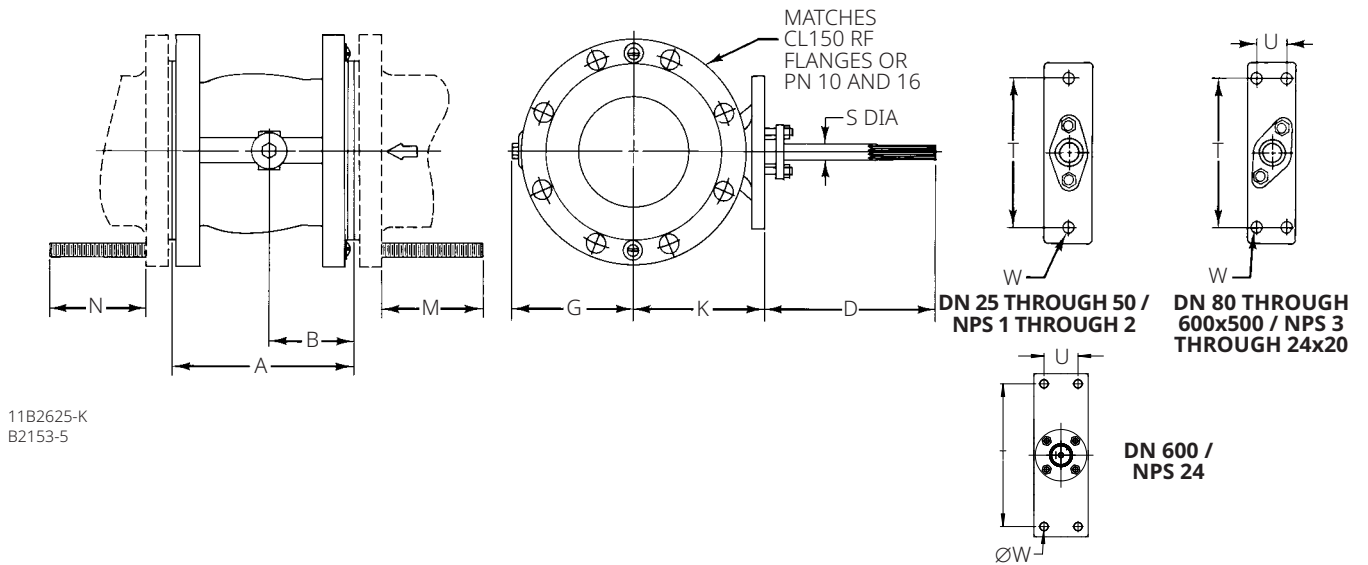

Figure 15. Fisher V200 Dimensions (also see Table 12)

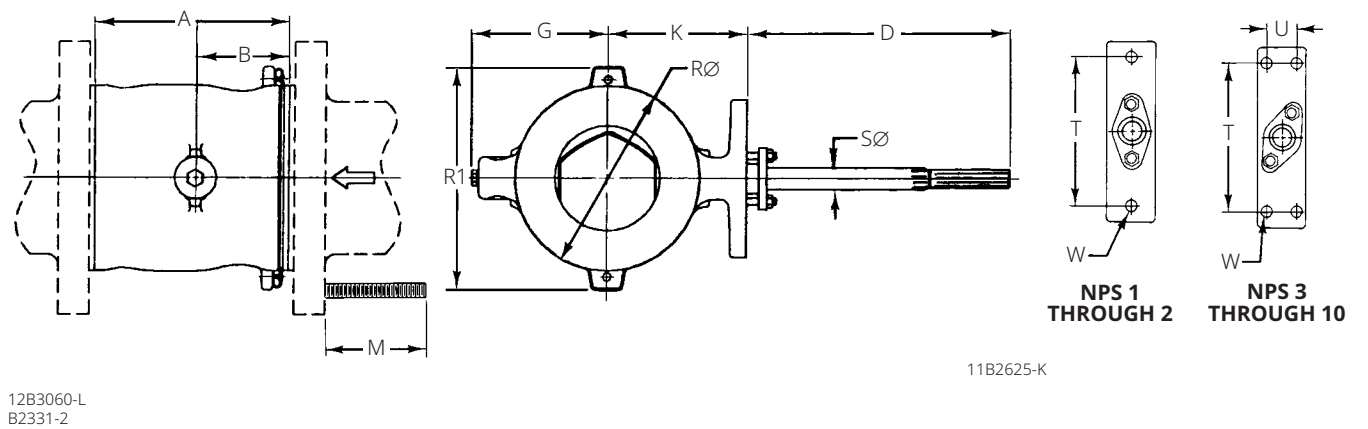

Figure 16. Fisher V200 CL600 Flanged Dimensions (also see Table 13)

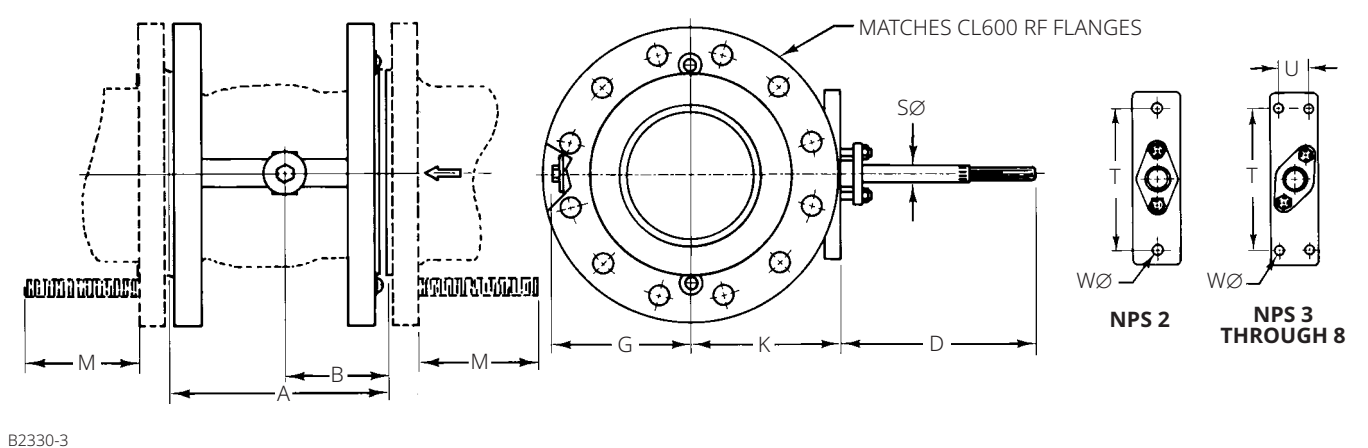

Table 12. Fisher V200 Flangeless Dimensions⁽¹⁾

VALVE SIZE, NPS	V200 DIMENSIONS (ISA S75.08.02)															ASME B16.5 RF FLANGES	APPROXIMATE WEIGHT	
	A	B	D	G	K	M			R	R1	S	T	U	W				
	mm														kg			
1	102	56		81	95	176	202	202	51	102	12.7					CL150, 300 and 600	4.3	
1-1/2	114	62	188	89	121	189	224	224	73	119	15.7 and 15.7 x 12.7	117	---	14.2			6.4	
2	124	67		106	127	211	236	236	92	137	15.7 and 15.7 x 12.7						10	
3	165	79		117	130	254	279	286	127	167	19.1				152 32 14.2		15	
4	194	101	214	133	141	286	305	343	157	197	19.1							22
6	229	109		159	164 ⁽¹⁾	343	362	413	216	260	25.4							27
8	243	124	208	195	232	343	387	426	270	314	31.8	235	46	17.5		62		
10	297	147		222	260	419	---	---	324	368								
in.																lbs		
1	4.00	2.21		3.19	3.75	6.94	7.94	7.94	2	4.00	1/2				CL150, 300 and 600	10		
1-1/2	4.50	2.46	7.38	3.50	4.75	7.44	8.81	8.81	2.88	4.68	5/8 and 5/8 x 1/2	4.62	---	0.56			14	
2	4.88	2.63		4.19	5.00	8.31	9.31	9.31	3.63	5.38	5/8 and 5/8 x 1/2						23	
3	6.50	3.10		4.62	5.12	10.00	11.00	11.25	5.00	6.56	3/4					6.00 1.25 0.56	34	
4	7.62	3.99	8.44	5.25	5.56	11.25	12.00	13.50	6.19	7.76	3/4							48
6	9.00	4.29		6.25	6.44 ⁽²⁾	13.50	14.25	16.25	8.50	10.24	1							60
8	9.56	4.88	8.19	7.69	9.12	13.50	15.25	16.75	10.63	12.38	1-1/4	9.25	1.81	0.69		136		
10	11.69	5.77		8.75	10.25	16.50	---	---	12.75	14.50								

1. Multi-class valves are not interchangeable because of line bolting requirements. Please select the appropriate valve based on the pressure class of your piping.
 2. 179 mm / 7.06 in. for NPS 6, CL600 valves only.

Table 13. Fisher V200 Flanged CL600 Dimensions

VALVE SIZE	DIMENSIONS (ANSI/ISA 75.08.02)													APPROXIMATE WEIGHT
	A ⁽²⁾	B	D	G	K	M (Qty) ⁽¹⁾	Bolt Size	Threaded Holes Per Flange	S Diameter	T	U	W		
DN	mm													kg
50	124	67	188	106	127	121 (16)	5/8-11 UNC	4	16	117	---	14.2	17	
80	165	79	214	117	130	140 (16)	3/4-10 UNC	4	19	152	32		28	
100	194	101	214	133	141	165 (16)	7/8-9 UNC	---	19	152	32	14.2	48	
150	229	109	214	159	164	197 (24)	1-8 UNC	2	25	152	32	14.2	93	
200	243	124	208	195	232	216 (24)	1-1/8-8 UNC	4	32	235	46	17.5	160	
NPS	in.													lbs
2	4.88	2.63	7.38	4.19	5.00	4.75 (16)	5/8-11 UNC	4	5/8	4.62	---	0.56	38	
3	6.50	3.10	8.44	4.62	5.12	5.50 (16)	3/4-10 UNC	4	3/4	6.00	1.25		61	
4	7.62	3.99	8.44	5.25	5.56	6.50 (16)	7/8-9 UNC	---	3/4	6.00	1.25	0.56	105	
6	9.00	4.29	8.44	6.25	6.44	7.75 (24)	1-8 UNC	2	1	6.00	1.25	0.56	205	
8	9.56	4.88	8.19	7.69	9.12	8.50 (24)	1-1/8-8 UNC	4	1-1/4	9.25	1.81	0.69	353	

1. For valve assemblies with the Cavitrol Hex anti-cavitation trim installed, the required outlet flange bolt length and the clearance necessary to remove the bolt will be 12.7 mm / 1/2 in. longer than dimension M specified.
 2. For valve assemblies with Cavitrol Hex anti-cavitation trim installed, dimension A will be 12.7 mm / 1/2 in. larger than specified.

Table 14. Fisher V300 Dimensions

VALVE SIZE	DIMENSIONS (ANSI/ISA 75.08.02)											APPROXIMATE WEIGHT	
	A ^(5,6)	B	D	G	K	M ^(3,6)	N ^(3,4)	S Diameter	T	U	W		
DN ⁽¹⁾	mm											kg	
25	102	56		81	95	100	94	13					8
40	114	62	188	89	121	114	108	16 and 16 X 13	117	---			12
50	124	67		106	127	106	100	16 and 16 X 13					17
80	165	79		117	130	133	121	19				14.2	28
100	194	101	214	133	141	140	127	19	152	32			37
150	229	109		159	164	152	140	25					60
200	243	124		195	232	165	152	32					103
250	297	147	208	222	260	186	173	32	235	46		17.5	200
300	338	174		268	303	198	186	38					293
350 ⁽²⁾	381	206	356	295	343	152	133	44.5	273	50.8	19.1		375
400 ⁽²⁾	406	229	356	330	365	152	133	54.0	273	50.8	19.1		511
500	508	235	356	406	457	224	203	63.5	337	76.2	22.4		755
600 ⁽⁶⁾	610	324	470	500	547	261	248	76.2	533	127.0	31.8		1308
NPS	in.											lbs	
1	4.00	2.21		3.19	3.75	3.94	3.69	1/2					17
1-1/2	4.50	2.46	7.38	3.50	4.75	4.50	4.25	5/8 and 5/8 X 1/2	4.62	---			27
2	4.88	2.63		4.19	5.00	4.19	3.94	5/8 and 5/8 X 1/2				0.56	38
3	6.50	3.10		4.62	5.12	5.25	4.75	3/4					61
4	7.62	3.99	8.44	5.25	5.56	5.50	5.00	3/4	6.00	1.25			81
6	9.00	4.29		6.25	6.44	6.00	5.50	1					133
8	9.56	4.88		7.69	9.12	6.50	6.00	1-1/4					226
10	11.69	5.77	8.19	8.75	10.25	7.31	6.81	1-1/4	9.25	1.81	0.69		440
12	13.31	6.87		10.56	11.94	7.81	7.31	1-1/2					645
14 ⁽²⁾	15.00	8.12	14.00	11.62	13.50	7.75	7.00	1-3/4	10.75	2.00	0.75		825
16 ⁽²⁾	16.00	9.00	14.00	13.31	14.38	8.25	7.50	2-1/8	10.75	2.00	0.75		1125
20	20.00	9.25	14.00	16.00	18.00	8.81	8.00	2-1/2	13.25	3.00	0.88		1661
24 ⁽⁶⁾	24.00	12.75	18.50	19.70	21.55	10.25	9.75	3	21.00	5.00	1.25		2877

1. DN 25, 40, 50, 80 and 100 are the only sizes offered in V300 for Europe.
 2. DN 350 and 400 / NPS 14 and 16 valves are available in ASME B16.10 short, only. See dimension A for ASME B16.10 short shown in Figure 18.
 3. Clearance necessary to remove flange bolts.
 4. For valve assemblies with the Cavitrol Hex anti-cavitation trim installed, the required outlet flange bolt length and the clearance necessary to remove the bolt will be 12.7 mm / 1/2 in. longer than dimension N specified. In this case, use dimension M to determine the outlet flange bolt length.
 5. For valve assemblies with Cavitrol Hex anti-cavitation trim installed, dimension A will be 12.7 mm / 1/2 in. larger than specified.
 6. For flangeless NPS 24 V150 and V300 options, see Table 17.

Figure 17. Fisher V300 Dimensions (also see Table 14)

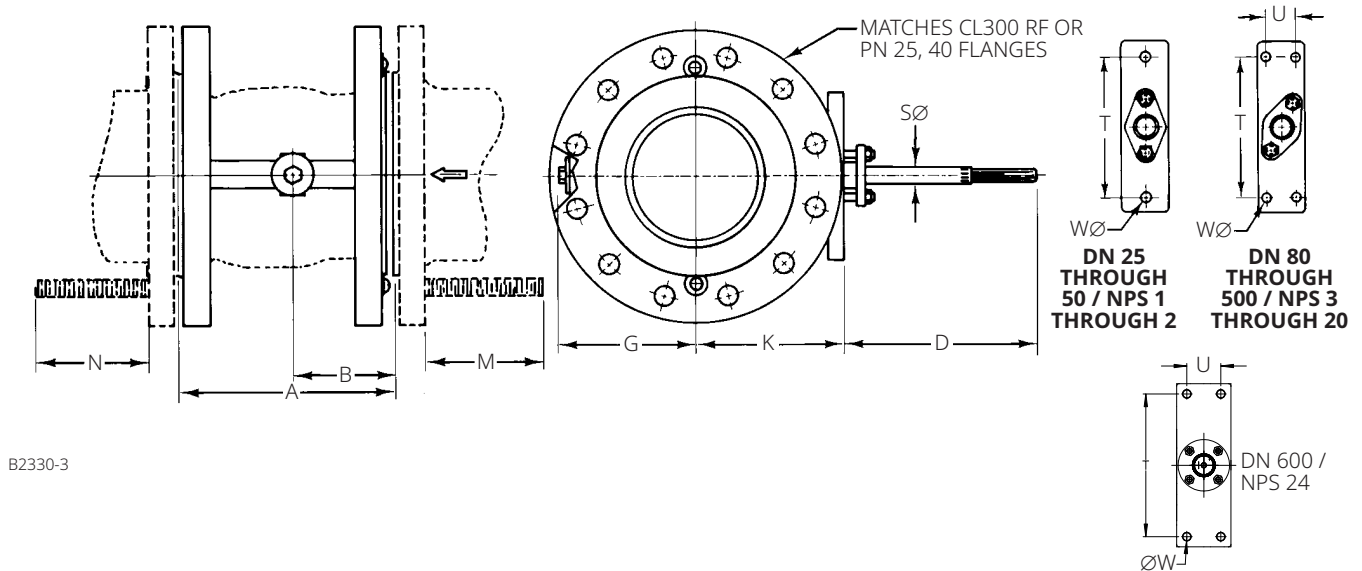

B2330-3

Table 15. Fisher V150 Optional Dimensions

V150 OPTIONAL DIMENSIONS FOR NPS 1 THROUGH 12 (ASME B16.10 SHORT)							
VALVE SIZE		A ⁽³⁾		M ⁽¹⁾		N ^(1,2)	
DN	NPS	mm	in.	mm	in.	mm	in.
25	1	127	5.00	103	4.06	71	2.81
40	1-1/2	165	6.50	135	5.31	78	3.06
50	2	178	7.00	155	6.11	92	3.61
80	3	203	8.00	142	5.61	98	3.86
100	4	229	9.00	155	6.11	98	3.86
150	6	267	10.50	163	6.40	112	4.40
200	8	292	11.50	182	7.15	124	4.90
250	10	330	13.00	176	6.94	132	5.19
300	12	356	14.00	170	6.69	132	5.19

1. Clearance necessary to remove flange bolts.
2. For valve assemblies with the Cavitrol Hex anti-cavitation trim installed, the required outlet flange bolt length and the clearance necessary to remove the bolt will be 12.7 mm / 1/2 in. longer than dimension N specified.
3. For valve assemblies with Cavitrol Hex anti-cavitation trim installed, dimension A will be 12.7 mm / 1/2 in. larger than specified.

Figure 18. Fisher V150 and V200 Optional Dimensions (also see Tables 15, 16 and 17)

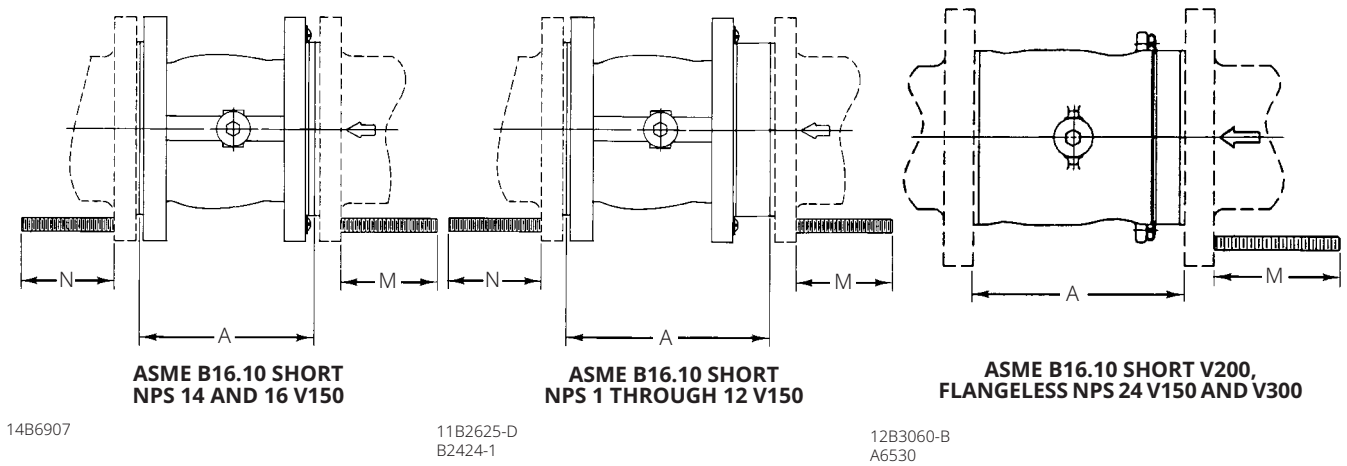

NOTES:

- NPS 1 THROUGH 12 VALVES ARE AVAILABLE WITH EITHER ISA S75.08.02 FACE-TO-FACE DIMENSIONS OR ASME B16.10 SHORT FACE-TO-FACE DIMENSIONS. NPS 1 THROUGH 12 VALVES WILL BE SUPPLIED IN ISA S75.08.02 UNLESS YOU SPECIFY OTHERWISE. NOTE THAT ASME B16.10 SHORT DIMENSIONS ARE ACTUALLY LONGER THAN ISA S75.08.02.
- NPS 14 AND 16 VALVES ARE AVAILABLE ONLY WITH ASME B16.10 SHORT FACE-TO-FACE DIMENSIONS.
- NPS 20 VALVES ARE AVAILABLE ONLY WITH A 508 MM / 20-IN. FACE-TO-FACE DIMENSION.
- M AND N DIMENSIONS SHOWN FOR V150 ARE CLEARANCE NECESSARY TO REMOVE FLANGE BOLTS.

Table 16. Fisher V200 Optional Dimensions

V200 OPTIONAL DIMENSIONS (ASME B16.10 SHORT) ^(1,2)		
VALVE SIZE, NPS	A	M
mm		
1	127	202
1-1/2	165	240
2	178	268
3	203	286
4	229	321
6	267	381
8	292	394
10	330	451
in.		
1	5.00	7.94
1-1/2	6.50	9.44
2	7.00	10.56
3	8.00	11.25
4	9.00	12.62
6	10.50	15.00
8	11.50	15.50
10	13.00	17.75

1. Available for CL150 valves only.
 2. ASME B16.10 short dimensions are actually longer than ISA S75.08.02 dimensions.

Figure 19. Fisher Vee-Ball Square Shaft Dimensions (also see Table 18)

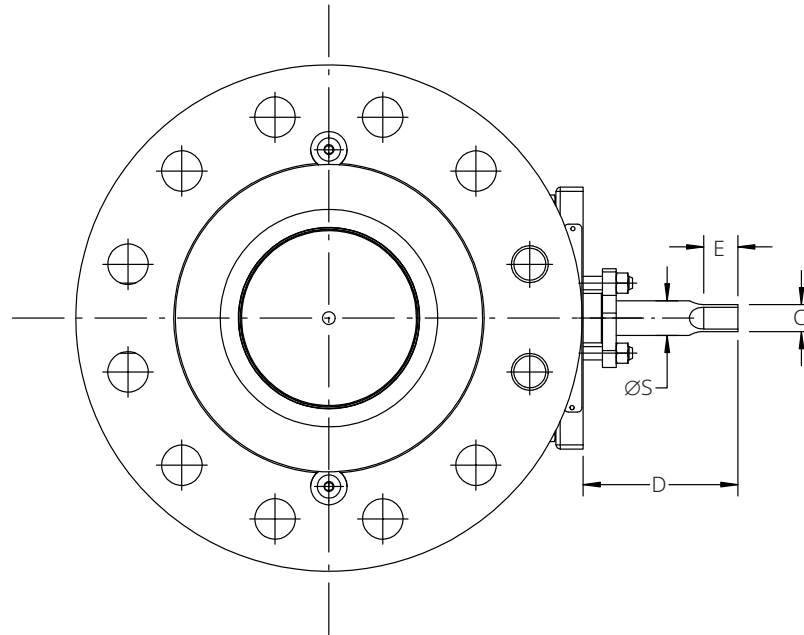

Table 17. Fisher NPS 24 V150 and V300 Optional Dimensions⁽¹⁾

VALVE TYPE	A	M ⁽²⁾	APPROXIMATE WEIGHT
	mm		kg
V150	508	686	521
V300		743	621
	in.		lb
V150	20	27.00	1147
V300		29.25	1367

1. Available for flangeless NPS 24 valves only.
2. Clearance necessary to remove flange bolts.

Table 18. Fisher Vee-Ball Square Shaft Dimensions

VALVE SIZE / PRESSURE RATING		C		D		E		S ⁽¹⁾	
		mm	in.	mm	in.	mm	in.	mm	in.
DN 25 / PN 10 to 40	NPS 1 / CL150 to 300	9.0	0.4	74.0	2.91	15.0	0.59	13.0	1/2
DN 40 / PN 10 to 40	NPS 1.5 / CL150 to 600	11.0	0.4	76.0	2.99	15.0	0.59	15.9	5/8
DN 50 / PN 10 to 40	NPS 2 / CL150 to 600	11.0	0.4	76.0	2.99	15.0	0.59	15.9	5/8
DN 80 / PN 10 to 40	NPS 3 / CL150 to 600	14.0	0.6	103.0	4.06	19.0	0.75	19.1	3/4
DN 100 / PN 10 to 40	NPS 4 / CL150 to 600	14.0	0.6	103.0	4.06	19.0	0.75	19.1	3/4
DN 150 / PN 10 to 40	NPS 6 / CL150 to 600	19.0	0.8	108.0	4.25	25.0	0.94	25.4	1
DN 200 / PN 10 to 40	NPS 8 / CL150 to 600	22.0	0.9	109.0	4.29	30.0	1.18	31.8	1
DN 250 / PN 10 to 40	NPS 10 / CL150 to 600	22.0	0.9	109.0	4.29	30.0	1.18	31.8	1-1/4
DN 300 / PN 10 to 25	NPS 12 / CL150 to 600	27.0	1.1	114.0	4.49	35.0	1.38	38.1	1-1/2
---	NPS 14 / CL150 to 300	---	1.4	---	6.25	---	1.77	---	1-3/4

1. This nominal Valve Shaft Diameter is the shaft diameter through the packing box. Use this diameter when selecting Fisher actuators.

Table 19. Fisher Vee-Ball Keyed Shaft Dimensions



VALVE SIZE, NPS	PRESSURE RATING	C		D		E		S ⁽¹⁾	
		mm	in.	mm	in.	mm	in.	mm	in.
24	CL300	69.9	2.75	394	15.51	111.3	4.38	76.2	3.00

1. This nominal valve shaft diameter is the shaft diameter through the packing box. Use this diameter when selecting Fisher actuators.

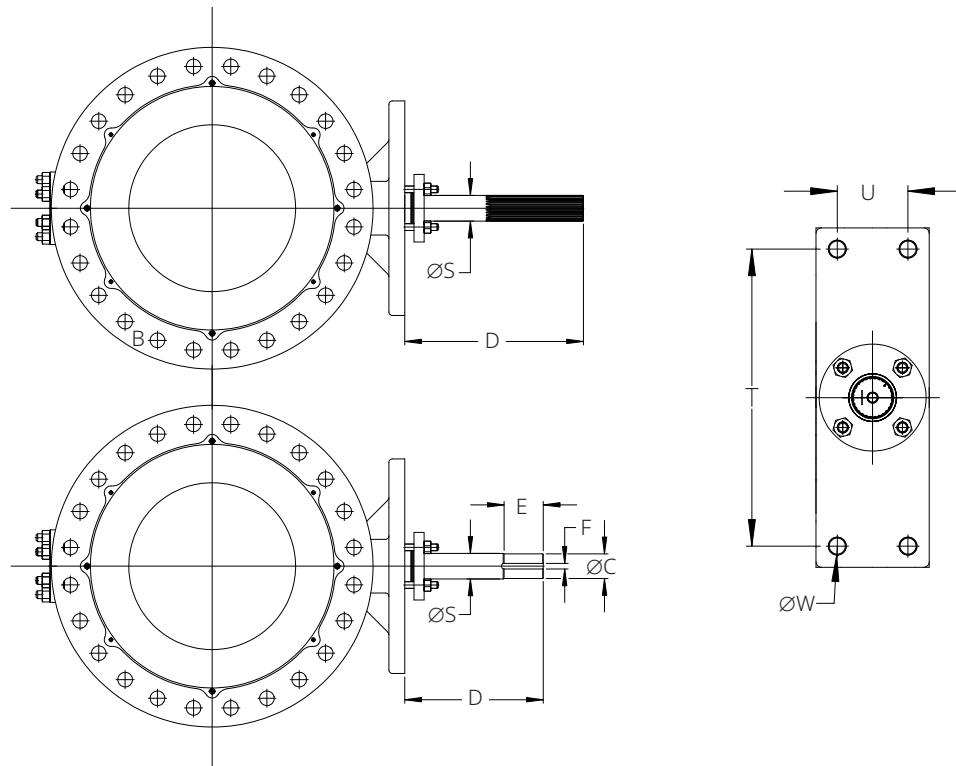
Figure 20. Fisher Vee-Ball Keyed Shaft Dimensions (also see Table 19)



21BA0124300

 [LinkedIn.com/groups/3941826](https://www.linkedin.com/groups/3941826)
 [Fisher.com](https://www.fisher.com)

 [Facebook.com/FisherValves](https://www.facebook.com/FisherValves)
 [X.com/FisherValves](https://www.x.com/FisherValves)

D101363X012 © 1990, 2025 Emerson. All rights reserved. The Emerson logo is a trademark and service mark of Emerson Electric Co. Fisher, Cavitrol, Vee-Ball, FIELDVUE, Whisper Trim, and ENVIRO-SEAL are each a mark of an entity in the Emerson family of businesses. All other marks are the property of their respective owners.

Neither Emerson nor any of its affiliated entities assume responsibility for the selection, use or maintenance of any product. Responsibility for proper selection, use, and maintenance of any product remains solely with the purchaser and end user.

The contents of this publication are presented for informational purposes only, and while every effort has been made to ensure their accuracy, they are not to be construed as warranties or guarantees, express or implied, regarding the products or services described herein or their use or applicability. All sales are governed by our terms and conditions, which are available upon request. We reserve the right to modify or improve the designs or specifications of such products at any time without notice.

Emerson
Marshalltown, Iowa 50158 USA
Sorocaba, 18087 Brazil
Cernay, 68700 France
Dubai, United Arab Emirates
Singapore 128461 Singapore

www.fisher.com

FISHER™

EMERSON™